

Operating instructions  
**Radar Level Sensor**  
**OTT RLS 500**

**OTT RLS 500 (HF)**

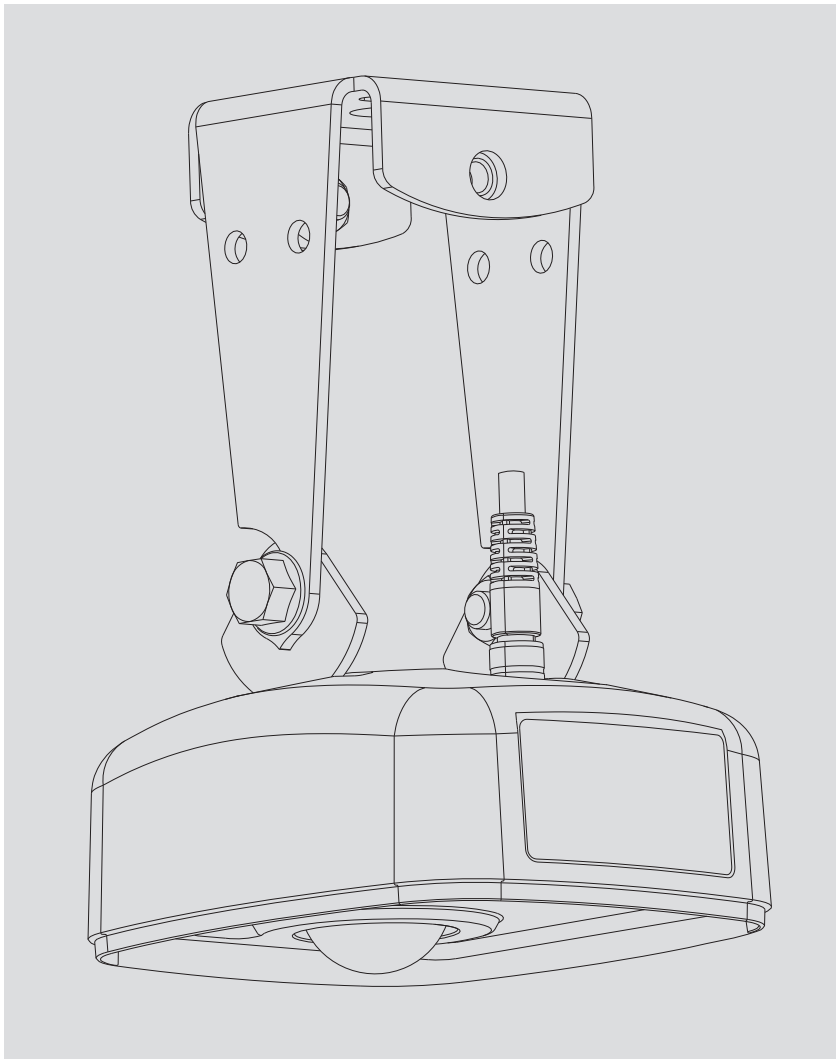

We reserve the right to make technical changes and improvements without notice.

## Table of contents

|   |           |
|---|-----------|
| <b>1 Scope of supply</b>  | <b>4</b>  |
| <b>2 Order numbers and variant code</b>   | <b>4</b>  |
| <b>3 Basic safety information</b>   | <b>7</b>  |
| 3.1 Markings and symbols used in the instruction  | 7         |
| 3.2 Explanation on safety information used  | 7         |
| 3.3 Note the following for safe and trouble-free operation of the OTT RLS 500 (HF)                              | 8         |
| <b>4 Introduction</b>   | <b>9</b>  |
| <b>5 Installing the OTT RLS 500 (HF)</b>  | <b>11</b> |
| 5.1 Criteria for selecting a suitable mounting location   | 11        |
| 5.2 Preparatory activities for accident prevention  | 13        |
| 5.3 Mounting the OTT RLS 500 (HF)   | 13        |
| 5.4 Connecting the OTT RLS 500 (HF) to OTT SensorLink 1000 datalogger   | 17        |
| 5.5 General information on the supply voltage   | 18        |
| 5.6 Wire assignment of connection cable   | 18        |
| 5.7 Connecting the OTT RLS 500 (HF) to any datalogger using an SDI-12 interface                                 | 19        |
| 5.8 Connecting the OTT RLS 500 (HF) to any datalogger/electronic control using an RS-485 interface              | 20        |
| 5.9 Connecting the OTT RLS 500 (HF) to the IP dataloggerOTT netDL using an SDI-12 or RS-485 interface           | 21        |
| 5.10 Connecting theOTT RLS 500 (HF) to the Sutron XLink 100/500 datalogger using an SDI-12- or RS-485 interface | 22        |
| 5.11 Connecting the OTT RLS 500 (HF) to the Sutron SatLink 3 datalogger using an SDI-12- or RS-485 interface    | 23        |
| <b>6 Configuring/testing the OTT RLS 500 (HF)</b>   | <b>24</b> |
| <b>7 SDI-12 commands and responses</b>  | <b>26</b> |
| 7.1 Overview of SDI-12 commands   | 26        |
| 7.2 Standard commands   | 30        |
| 7.3 Meta data commands  | 37        |
| 7.4 Advanced SDI-12 commands  | 39        |
| <b>8 RS-485 interface with Modbus protocol (RTU)</b>  | <b>47</b> |
| 8.1 Preconditions   | 47        |
| 8.2 Value ranges  | 47        |
| 8.3 Sensor description register   | 48        |
| 8.4 Register of sensor values   | 51        |
| 8.5 Configuration register  | 52        |
| <b>9 Carrying out maintenance work</b>  | <b>54</b> |
| <b>10 Troubleshooting</b>   | <b>55</b> |
| <b>11 Repair</b>  | <b>56</b> |
| <b>12 Note about the disposal of old units</b>  | <b>56</b> |
| <b>13 Technical data</b>  | <b>57</b> |
| <b>Annex A – Dimensions housing- / wall bracket</b>   | <b>59</b> |
| <b>Annex B – Definition of X-/Y-axes and direction of rotation</b>  | <b>60</b> |
| <b>Annex C – Note on Declaration of Conformity</b>  | <b>61</b> |
| <b>Annex D – Declaration of Health</b>  | <b>61</b> |

## 1 Scope of supply

- ▶ **OTT RLS 500**
  - 1 Radar sensor OTT RLS 500 for contactless measurement of the levels of surface water; communication protocol of the RS-485 interface, preset measured value units and accessories included in the scope of supply  
→ see Chapter 2, *Order numbers and variant code*
  - 1 Factory acceptance test certificate (FAT)
- ▶ **OTT RLS 500 HF**
  - like OTT RLS 500;
  - additionally with increased, adjustable sampling rate (repetition rate of individual distance measurements)

## 2 Order numbers and variant code

### 2.1 Valid for: all countries worldwide; exception USA

|                         |  |  |
|-------------------------|--|--|
| ▶ <b>OTT RLS 500</b>    | <p><b>Radar sensor</b></p> <p>Variant code (supplementary to order number)</p> <ul style="list-style-type: none"> <li>- Communication protocol of RS-485 interface</li> <li>- preset measurement units</li> <li>- Connection-*/Connecting cable**<br/>M9 socket ↔ open wires*</li> <li>M9 socket ↔ M9 connector**</li> <li>- Cable length</li> <li>- Installation accessories</li> <li>- Operating instructions</li> </ul>   | <p>6311000190</p> <p>-□-□-□-□□-□-□</p> <p>S</p> <p>M</p> <p>M</p> <p>I</p> <p>O</p> <p>W</p> <p>P</p> <p>00</p> <p>05</p> <p>10</p> <p>30</p> <p>50</p> <p>02</p> <p>04</p> <p>08</p> <p>20</p> <p>0</p> <p>M</p> <p>O</p> <p>D</p> <p>E</p> <p>F</p> <p>S</p> |
| ▶ <b>OTT RLS 500 HF</b> | <p><b>Radar sensor with increased sampling rate</b></p> <p>Variant code like OTT RLS 500</p>   | <p>6311000290</p>  |
| ▶ <b>Accessories</b>    | <p><b>Wall bracket</b></p> <ul style="list-style-type: none"> <li>- for mounting the OTT RLS 500 (HF)</li> <li>- combining the housing- and wall bracket enables to swivel mount the radar sensor</li> <li>- alignment to the water surface possible in <b>two</b> axes</li> </ul> <p><b>Housing bracket</b></p> <ul style="list-style-type: none"> <li>- for mounting the OTT RLS 500 (HF)</li> <li>- alignment to the water surface possible in <b>one</b> axis</li> <li>- to be ordered separately/as spare part</li> </ul> | <p>6310540631</p> <p>6311040331</p>  |

► **Accessories**

**Connection-\*/Connecting cable\*\***

6311000392

Variant code (supplementary to order number)

-□-□□

- Connection-\*/connecting cable\*\*

M9 socket ↔ open wires\*

W

M9 socket ↔ M9 connector\*\*

P

- Cable lengths 5 meters\*

05

10 meters\*

10

30 meters\*

30

50 meters\*

50

2 meters\*\*

02

4 meters\*\*

04

8 meters\*\*

08

20 meters\*\*

20

**OTT USB/SDI-12 Adapter**

6505000292

- for temporary connection of OTT sensors with SDI-12- or RS-485 interface to a PC

- USB connection cable included; USB plug A to USB plug B; 3 m

**Examples**

OTT RLS 500

- SDI-12 interface

- metric measurement units

- Connecting cable, M9 socket ↔ M9 connector; 2 meters cable lengths

- with housing bracket

- Operating instructions in French

→ Order number + Variant code: 6311000190-S-M-P-02-M-F

Connection cable

- M9 socket ↔ open wires

- 30 meters cable lengths

→ Ordner number + variant code: 6311000392-W-30

## 2.2 Valid for: USA

### ▶ OTT RLS 500

#### Radar sensor

Variant code (supplementary to order number)

- Communication protocol of RS-485 interface SDI-12  
Modbus
- preset measurement units metric  
imperial
- Installation accessories w/o  
with housing bracket

RLS500  
- □ - □ - □ - □ □ - □ - □  
S  
M  
M  
I  
0  
M

### ▶ OTT RLS 500 HF

#### Radar sensor with increased sampling rate

Variant code like OTT RLS 500

RLS500HF

### ▶ Operating instructions OTT RLS 500 (HF)

English  
German  
French  
Spanish

RLS500-Manual-E  
RLS500-Manual-D  
RLS500-Manual-F  
RLS500-Manual-S

### ▶ Accessories

#### Connection cable

Variant code (supplementary to order number)

- M9 socket ↔ open wires\*
- M9 socket ↔ M9 connector\*\*
- Cable lengths 5 m / 17 ft\*  
10 m / 33 ft\*  
30 m / 99 ft\*  
50 m / 165 ft\*  
2 m / 7 ft\*\*  
4 m / 14 ft\*\*  
8 m / 27 ft\*\*  
20 m / 65 ft\*\*

RLS500-CBL  
- □ - □ □  
W  
P  
05  
10  
30  
50  
02  
04  
08  
20

#### Wall bracket

- for mounting the OTT RLS 500 (HF)
- combining the housing- and wall bracket enables to swivel mount the radar sensor
- alignment to the water surface possible in **two** axes

RLS500-swmount

#### Housing bracket

- for mounting the OTT RLS 500 (HF)
- alignment to the water surface possible in **one** axis
- o be ordered separately/as spare part

RLS500-mount

### Examples

OTT RLS 500

- SDI-12 interface
- imperial measurement units
- with housing bracket

→ Order number + variant code: RLS500-S-I-M

Connecting cable

- M9 socket ↔ open wires
- 30 m / 99 ft cable lengths

→ Order number + variant code: RLS500-CBL-W-30

## 3 Basic safety information

### 3.1 Markings and symbols used in the instruction

- This bullet point indicates an instruction relating to a specific action.
- ▶ This bullet point indicates an item in a list.
  - This bullet point indicates a sub-item in a list.

- **Remarks: ...**
  - ▶ Information on easier and more efficient work
  - ▶ Further information
  - ▶ Definition

- ! **Please note: ...**  
Information that prevents potential damage or malfunction on the OTT RLS 500 (HF).

### 3.2 Explanation on safety information used

The safety information used in these operating instructions is classified according to the nature and severity of a particular hazard. The hazard levels defined are indicated by the signal words **Warning/Caution** and corresponding pictograms **orange/yellow triangle** in these operating instructions.

---

#### **WARNING**

#### **Warning of a hazardous situation with a medium level of risk**



The safety information specifies the nature and source of the hazard. If you fail to carry out the specified actions, the hazardous situation can result in **death** or **serious injuries**.

- ▶ Action to prevent the hazardous situation!
- ▶ Action to prevent the hazardous situation!

---

#### **CAUTION**

#### **Warning of a hazardous situation with a low level of risk**



The safety information specifies the nature and source of the hazard. If you fail to carry out the specified actions, the hazardous situation can result in **minor** or **moderately severe injuries**.

- ▶ Action to prevent the hazardous situation!
  - ▶ Action to prevent the hazardous situation!
-

### 3.3 Note the following for safe and trouble-free operation of the OTT RLS 500 (HF)

- ▶ This manual is intended for professional specialist personnel who carry out work with hydrological radar sensors.
- ▶ Read these operating instructions before using the OTT RLS 500 (HF) for the first time! Make yourself completely familiar with the installation and operation of the OTT RLS 500 (HF)! Retain these operating instructions for later reference.
- ▶ *Intended use* Only use the OTT RLS 500 (HF) as described in these operating instructions! The intended use of the OTT RLS 500 (HF) is the contactless measurement of the water level of surface waters (hydrometry). Any other use is not permitted! Further information → see Chapter 4, *Introduction*.
- ▶ Never operate the OTT RLS 500 (HF) in explosive areas! Further information → see Chapter 5, *Installing the OTT RLS 500 (HF)*.
- ▶ Personnel installing the OTT RLS 500 (HF) must have the appropriate qualification! If required, OTT HydroMet can provide trainings. Further information → see Chapter 5, *Installing the OTT RLS 500 (HF)*.
- ▶ Only install the OTT RLS 500 (HF) in a fixed position and only direct the transmitting antenna downwards (sensor measuring beam must radiate downwards)! Further information → see Chapter 5, *Installing the OTT RLS 500 (HF)*.
- ▶ Note all the detailed safety and warning information given within the individual work steps during installation and maintenance. Further details on the structure and design of warning information → see Chapter 3.2, *Explanation on safety information used*.
- ▶ If the OTT RLS 500 (HF) is powered directly by a battery/rechargeable battery: Protect the supply line from the battery/rechargeable battery to the radar sensor with a fuse! Rated current: 0.250 amperes; Reaction time: fast. (Not required in conjunction with an OTT SensorLink 1000, as this already contains an appropriate fuse.) Further information → see Chapter 5, *Installing the OTT RLS 500*.
- ▶ It is essential to comply with the electrical, mechanical and climatic specifications given in the Technical Data section! Further information → see Chapter 13, *Technical Data*.
- ▶ Do not make any changes or retrofits to the OTT RLS 500 (HF)! If changes or retrofits are made, all guarantee claims are voided. Furthermore, the radio approval required for its operation is void.
- ▶ Check the OTT RLS 500 (HF) at regular intervals for correct alignment, heavy soiling, secure fastening, corrosion of the metal parts and mechanical damage. Further information → see Chapter 9, *Carrying out maintenance work*.
- ▶ Have a faulty OTT RLS 500 (HF) inspected and repaired by our repair center. Never make any repairs yourself under any circumstances! Further information → see Chapter 11, *Repair*.
- ▶ Dispose of the OTT RLS 500 (HF) properly after taking out of service. Never put the OTT RLS 500 (HF) into the normal household waste. Further information → see Chapter 12, *Note about the disposal of old units*.
- ! ▶ The product has only the listed approvals and the official registrations, certificates and declarations supplied with the product. The use of this product in an application for which it is not approved is not authorized by the manufacturer.



## 4 Introduction

The OTT RLS 500 and OTT RLS 500 HF radar sensors are used for precise, non-contact measurement of water levels in surface waters.

Operation of the OTT RLS 500 (HF) is based on FMCW radar technology. The radar sensor transmits a frequency-modulated continuous wave signal in the 77 to 81 GHz frequency range (W band). The distance is then measured using an indirect transit time measurement by comparing the frequency of the received signal - reflected from the water surface - with the transmitted signal. The radar sensor then automatically calculates the actual water level of the body of water. For this purpose, it is possible to enter the corresponding measurement mode and a reference value during commissioning.

The OTT RLS 500 performs a sampling of the water surface within one second, the OTT RLS 500 HF optionally 1, 2, 4 or 8 samplings; duration 100 milliseconds in each case. An OTT RLS 500 (HF) measuring interval is defined as the arithmetic mean value of several scans over an adjustable averaging time. The averaging time is 1 ... 60 seconds (corresponding to 1 ... 480 samples); factory setting: 1 second).

In addition to the measured water level, the OTT RLS 500 (HF) also records other operating parameters and makes them available as metadata. This enables comprehensive remote monitoring of the radar sensor. Statistical data is also determined within each measurement interval.

Fig. 1: Overview radar sensor OTT RLS 500 (HF).

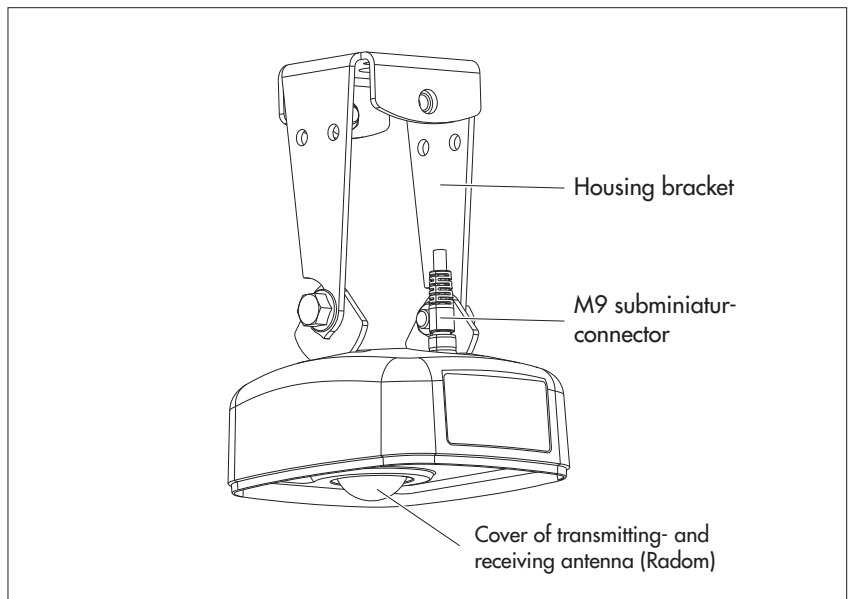

A physical SDI-12 and RS-485 interface are available for connecting the OTT RLS 500 (HF) to data collectors or peripheral devices. With the RS-485 interface, communication with the radar sensor takes place via SDI-12 or Modbus (RTU) transmission protocol, depending on the device variant selected.

The radar sensor can be configured either via the SDI-12 transparent mode of a data collector, via Modbus (RTU) configuration registers or via the OTT USB/ SDI-12 adapter (accessory).

The transmitting antenna has a beam angle of approx. 8°. The resulting sensor measuring beam and the illumination zone on the surface of the water can be seen in Figures 2 to 4.

In combination with the OTT SensorLink 1000 compact data collector, a self-sufficient, solar-powered compact measuring station with integrated remote data transmission can be realized.

The radar sensor is installed using a swivel housing bracket. Combined with an optional wall bracket it is possible to swivel mount the sensor. This enables parallel alignment to the water surface, even on inclined surfaces. The electrical connection is made via a factory-assembled 7-pin M9 subminiature connector.

When using the RS-485 interface, a cable length of up to 1000 meters is possible between the radar sensor and the data collector; the cable length when using the SDI-12 interface is 200 m (depending on the wire cross-section used).

The entire radar sensor is designed to be flood-proof, provided it is installed correctly as described in these operating instructions.

Fig. 2: Example of use 1 – Installation of the OTT RLS 500 (HF) on a bridge.

The footprint on the water surface (shown in light blue) is approximately circular.

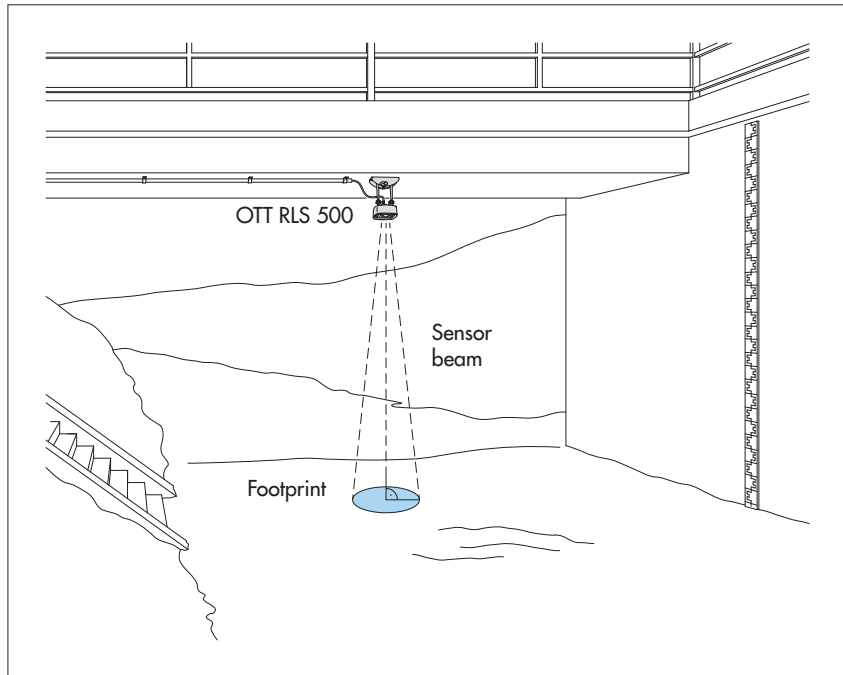
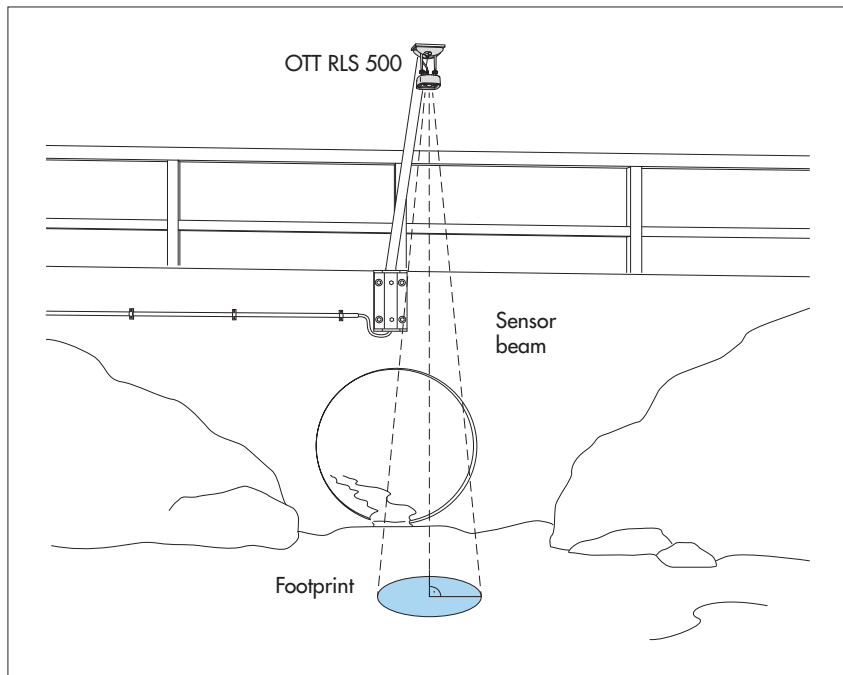

Fig. 3: Example of use 2 – Installation of the OTT RLS 500 (HF) at an auxiliary construction, e.g. metal stand with mounting plate.



## 5 Installing the OTT RLS 500 (HF)

### WARNING Danger of explosion due to spark formation and electrostatic discharge



The use of the OTT RLS 500 (HF) in explosive atmospheres can lead to the danger of ignition of this atmosphere. An explosion resulting from this involves the risk of very severe material and personal damage.

- ▶ **Never** operate the OTT RLS 500 (HF) in explosive areas (e.g. in sewers).  
The OTT RLS 500 (HF) is not equipped with *EX-protection* (Explosion protection)!

### 5.1 Criteria for selecting a suitable mounting location

- ▶ Possible mounting locations are, for example, bridges and auxiliary constructions directly above the waterway section to be measured.
- ▶ The mounting point must be steady. Vibrations and movement of the mounting point must be avoided. Bridges are affected by movements of several centimeters as a result of load changes and temperature movements. If pillars are available, the sensor can be mounted to a stable positioned pillar with a suitable spacer.
- ▶ The area within the sensor beam must be completely free of obstructions. The table in the figure serves to approximately determine the diameter of the footprint on the water surface (shown in light blue). The diameters given are minimum sizes. Where possible, select an area free of obstruction that is clearly larger.

Fig. 4: Sensor beam and footprint of the OTT RLS 500 (HF).

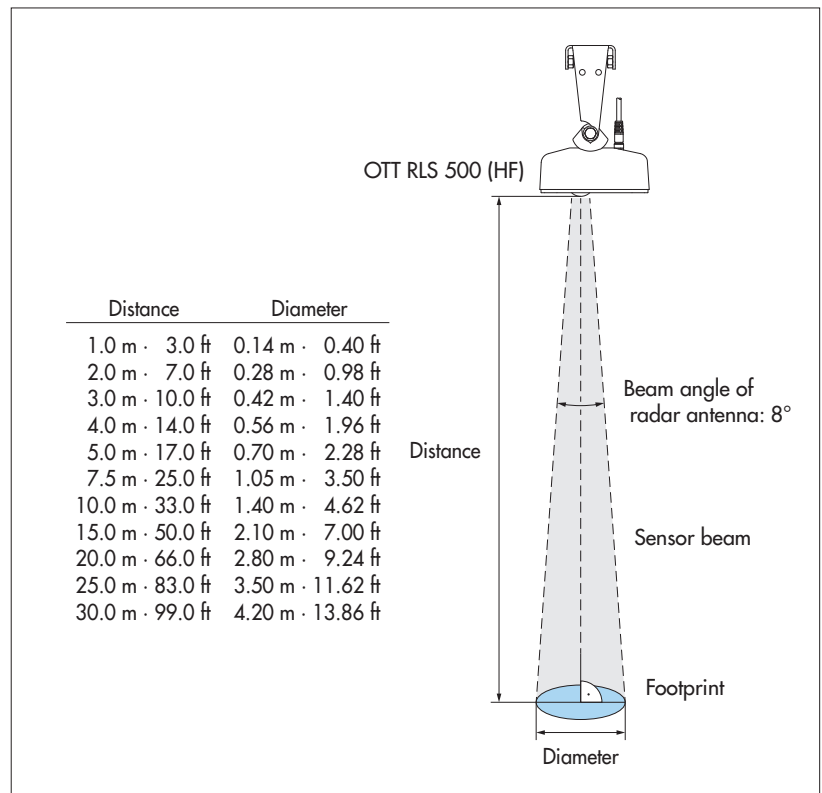

- ▶ The water surface must be as smooth as possible in the area of the sensor beam: avoid turbulent areas, areas where foam is created, surge areas and waterway sections where obstructions or bridge piers cause changes in the water level. The measurement result cannot be used if there is ice or snow on the water surface.
- ▶ A minimum distance between the lower edge of the sensor and the water surface is not required. Recommended: Select a distance that prevents the sensor from being flooded.
- ▶ Select the mounting point in such a way
  - that measurement is also possible in the event of high water;
  - that it does not fall dry at low water.
- ▶ Avoid large metal surfaces near the sensor beam. (Reflections from these surfaces can distort the measurement result).
- ▶ The climate specifications in the Technical Data must be kept to at the mounting location.
- ▶ When used in level and measuring wells, ensure that:
  - the sensor is correctly aligned;
  - the well remains clean and free of debris;
  - long measurement/averaging times or the factory settings for metal wells are used, especially for noisy measurements;
  - the well is large enough to take the diameter of the sensor beam. Ideally, the well should be two to three times the diameter of the sensor footprint (see Fig.4).
- ▶ The OTT RLS 500 (HF) complies with the requirements of the harmonized European standard "ETSI EN 302 729 V2.1.1 (2016)" for a "Level Probing Radar". This standard requires radio protection zones in the vicinity of radio astronomical equipment. As a result, two conditions must be met during installation:
  - Minimum distance of the OTT RLS 500 (HF) to radio astronomical facilities: 4 km. (Exception: a special permission has been granted by the responsible national regulatory authority.)
  - Within a radius of 4 ... 40 km around radio astronomical facilities: OTT RLS 500 (HF) may be installed at a maximum height of 15 m above the surrounding ground surface.

Affected radio astronomical facilities in the frequency range 75 ... 85 GHz:

| Country | Station name    | Latitude    | Longitude   |
|---------|-----------------|-------------|-------------|
| Germany | Effelsberg      | 50°31'32" N | 06°53'00" O |
| Finland | Metsähovi       | 60°13'04" N | 24°23'37" O |
| France  | Plateau de Bure | 44°38'01" N | 05°54'26" O |
| Italy   | Sardinia        | 39°29'50" N | 09°14'40" O |
| Sweden  | Onsala          | 57°23'45" N | 11°55'35" O |
| Spain   | Yebes           | 40°31'27" N | 03°05'22" W |
|         | Pico Veleta     | 37°03'58" N | 03°23'34" W |

! **Please note:** When operating several radar sensors with the same transmission frequency (OTT RLS 500, third-party products) at one measuring point, a minimum distance of 5 meters must be maintained between them!

## 5.2 Preparatory activities for accident prevention

- If there is a risk to third parties during installation: temporarily cordon off the installation site and put up a warning sign.
- Inform all persons present during the installation about potential hazards!
- Observe all other occupational safety measures!

## 5.3 Mounting the OTT RLS 500 (HF)

### **WARNING** Risk of falling when working at great heights and risk of drowning



In many cases, installation and maintenance of the OTT RLS 500 (HF) is carried out at great heights (→ risk of falling) and over deep/fast flowing water (→ risk of drowning).

- ▶ When working at great heights/in case of drowning risk, wear "Personal protective equipment" (PPE) for fall protection and protection against drowning.

### **CAUTION** Risk of injury from falling objects



When installing the OTT RLS 500 (HF), parts may accidentally come loose and fall down. There is a risk of injury to the entire body, especially when working above the head.

- ▶ Ensure that there are no other persons under the device to be installed!
- ▶ Wear a protective helmet and safety shoes during installation!

### **Options for mounting the OTT RLS 500 (HF)**

- ▶ **With housing bracket**
  - alignment to the water surface is possible in **one axis**
  - included in the scope of delivery
  - for details see "Fastening the housing bracket"

Fig. 5: OTT RLS 500 (HF) – potential swivel range when mounted with housing bracket.

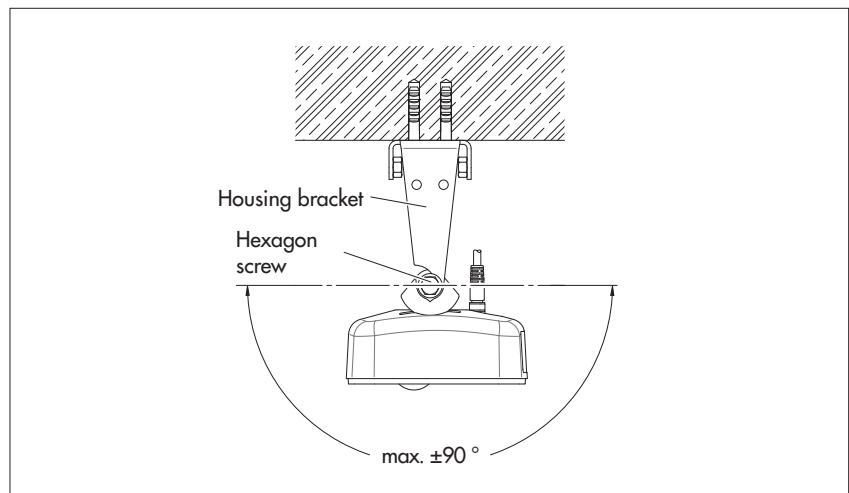

- ▶ with **swivel mount**
  - alignment to the water surface is possible in **two axes**
  - requires an additional wall bracket; see accessories
  - for details see "Fastening the swivel mount"

Fig. 6: OTT RLS 500 (HF) – potential range with swivel mount.

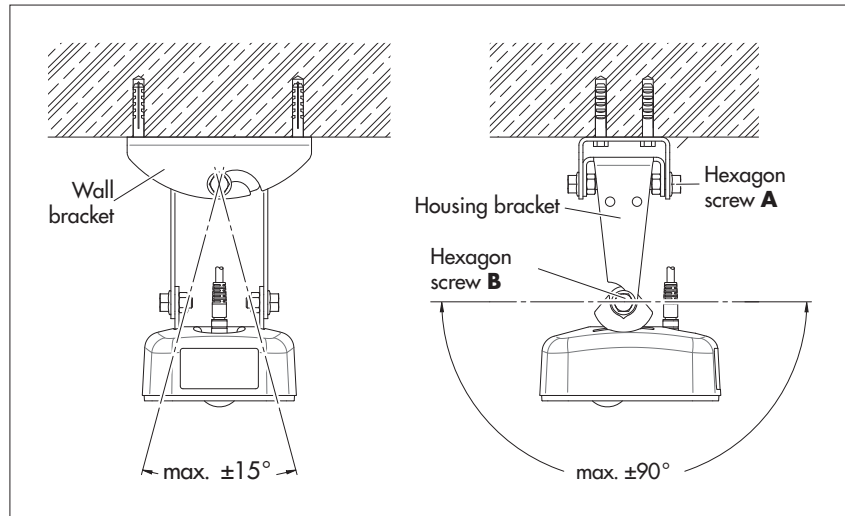

**CAUTION Risk of eye injuries from drilling dust**



Drilling is required when fastening the housing-/wall bracket. The resulting drilling dust can cause eye irritation/injury.

- ▶ Wear safety goggles when drilling!

**CAUTION Risk of crushing fingers/hands during installation**



When fastening the wall bracket/housing bracket and when aligning the housing, fingers/hands can be trapped or crushed.

- ▶ Wear protective gloves during installation!

**Fastening the housing bracket**

**Variant A**

- ▶ Mounting surface: concrete or masonry
- ▶ Fastening material: e.g. hexagon wood screws M6 x 40 + plastic dowels
- ▶ Dimensions housing- / wall bracket: see Annex C.

- Make two holes (Ø 8 mm · 5/16") using a hammer drill. (use housing bracket as a template for position of holes).
- Insert plastic dowels into drilled holes.
- Fasten the housing bracket with the hexagon wood screws.

**Variant B**

- ▶ Mounting surface: auxiliary construction, e.g. metal stand with mounting plate
- ▶ Fastening material: e.g. hexagon screw M12 x 25 + hexagon nut M12 + washers

- Drill a hole (Ø 13 mm · 1/2") in the steel structure.
- Fasten the housing bracket with hexagon screw, washers and hexagon nut.

## Fastening the swivel mount

### Variant A

- ▶ Suitable ground: concrete or masonry
- ▶ Fastening material: e.g. hexagon wood screws M6 x 40 + plastic dowel
- ▶ Dimensions housing- / wall bracket: see Annex C.
- Make two holes ( $\varnothing 8 \text{ mm} \cdot 5/16''$ ) using a hammer drill.  
(use wall bracket as a template for position of holes).
- Insert plastic dowels into drilled holes.
- Fasten wall bracket with hexagon wood screws.
- Insert housing bracket (without sensor) into wall bracket and lightly tighten the hexagon screws **A** (see Fig. 6).

### Variant B

- ▶ Mounting surface: auxiliary construction, e.g. metal stand with mounting plate
- ▶ Fastening material: e.g. hexagon screw M12 x 25 + hexagon nut M12 + washers
- Drill a hole ( $\varnothing 13 \text{ mm} \cdot 1/2''$ ) in the steel structure.
- Fasten the wall bracket with hexagon screw, washers and hexagon nut.
- Insert housing bracket (without sensor) into wall bracket and lightly tighten the hexagon screws **A** (see Fig 6).

Fig. 7: Fasten the wall bracket of the swivel mount.  
Fastening of the housing bracket is carried out in the same way.

Both methods are examples and are possible for wall and ceiling installations.

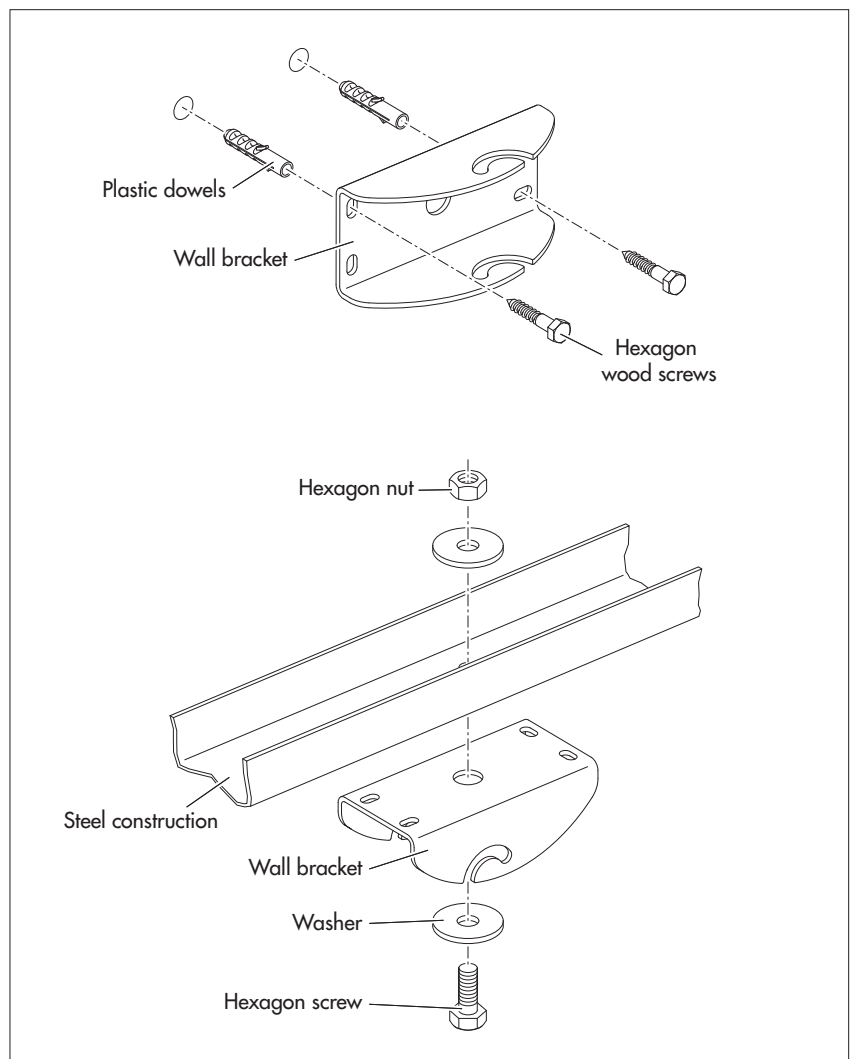

## Connecting connection/connecting cable to the OTT RLS 500 (HF)

Accessories required:

▶ Connecting cable; both ends assembled with M9 subminiature connectors;  
available lengths: 2, 4, 8 and 20 meters

or

▶ Connection cable, one end assembled with M9 subminiature connector;  
available lengths: 5, 10, 30 and 50 meters

! **Please note:** No moisture may get into the cable socket/plug! Protect the OTT RLS 500 (HF) from precipitation during installation! Penetrating moisture can lead to malfunctions and corrosion.

- Align the cable socket in the correct position (note the coding lug) and place it on the installation plug of the OTT RLS 500 (HF); see Fig. 8/9, step 1.
- Tighten the union nut by hand; see Fig. 8/9, step 2.
- Guide the connection/connecting cable upwards in a loop and secure it to the housing bracket with a cable tie (strain relief).

## Aligning the OTT RLS 500 (HF) parallel to the water surface

- Insert sensor into housing bracket and lightly tighten the hexagon screws (B) (see Fig. 5 and 6).
- Align the housing parallel (longitudinal and lateral axis) with the water surface using a bubble level.
- Tighten the hexagon screws (B) carefully.
- Only with swivel mount: tighten hexagon screws (A) carefully.
- Check alignment of the OTT RLS 500 (HF) again!

! **Please note:** the alignment of the sensor parallel to the water surface must be carried out as accurately as possible. Deviation from the parallel alignment leads to a linearity error.

• **Remark:** The OTT RLS 500 (HF) contains one inclination sensor for the X-axis and one for the Y-axis. Via the SDI-12 commands `aV!`, `aD0!` (value 3; X-axis) and `aD1!` (value 1; Y-axis) the current tilt angles can be retrieved. This is also possible via the Modbus register numbers 223 (register start address: 222; X-axis) and 225 (register start address: 224; Y-axis).



## 5.4 Connecting the OTT RLS 500 (HF) to OTT SensorLink 1000 datalogger

Combination of radar sensor OTT RLS 500 (HF) with OTT SensorLink 1000 datalogger: the electrical connection is made via a factory-assembled connecting cable with M9 subminiature connectors (accessories). The connecting cable is used for both power supply and data transmission.

- Align the connector in the correct position (note the coding lug) and place it on the installation plug of the OTT SensorLink 1000; see Fig 8, step 1.
- Tighten the union nut by hand; see Fig. 8, step 2.

Fig. 8: Connecting the OTT RLS 500 (HF) to OTT SensorLink 1000 datalogger.

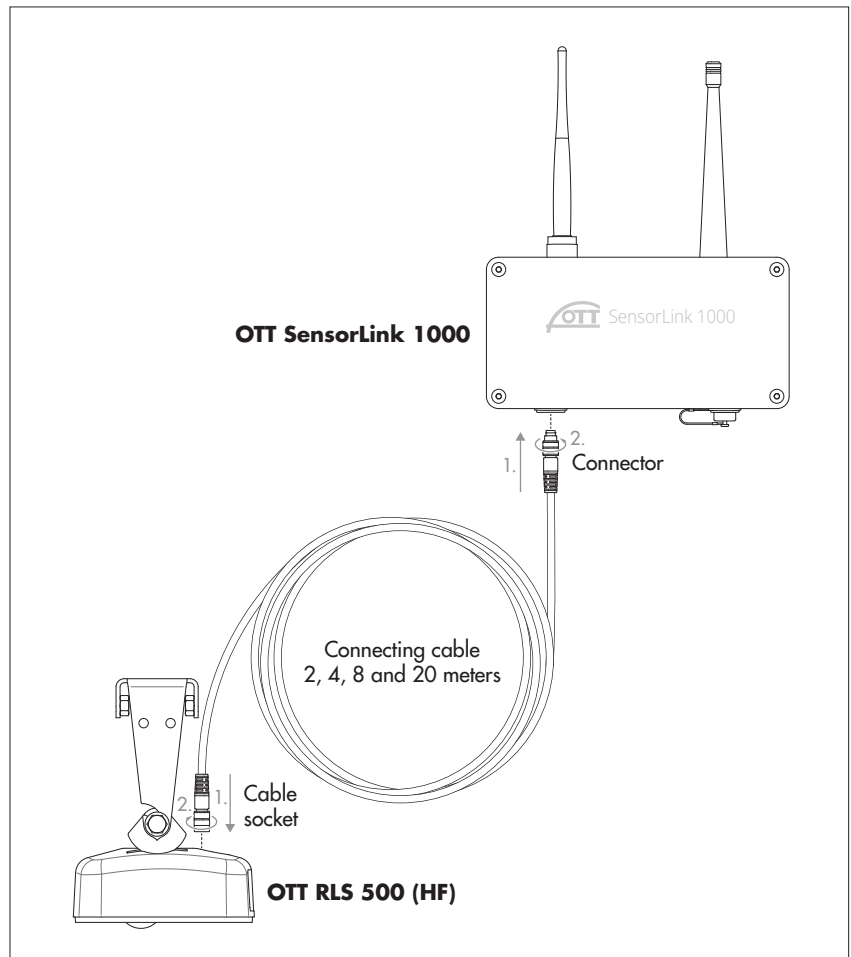

! **Please note:** Connecting the OTT RLS 500 (HF) to the compact datalogger OTT SensorLink 1000 overwrites all previous settings/operating parameters in the OTT RLS 500 (HF). For this application, configuration is carried out via "LinkComm" (operating software) of OTT HydroMet. Further information → see "Operating instructions Compact datalogger OTT SensorLink 1000".

### 5.5 General information on the supply voltage

The OTT RLS 500 (HF) requires a supply voltage of 5.5 ... 28.8 V DC, typ. 12/24 V<sub>DC</sub> (e.g. via rechargeable battery or via mains connection with electrically isolated safety extra-low-voltage).

The OTT RLS 500 (HF) is ready for operation as soon as the supply voltage is applied.



**Please note:**

- ▶ The electrical installation of the OTT RLS 500 (HF) may only be carried out by a specialist (e.g. specially trained electrician)!
- ▶ If the OTT RLS 500 (HF) is powered directly by a battery/rechargeable battery: Protect the supply line from the battery/rechargeable battery to the radar sensor with a fuse! Rated current: 0.250 amperes; reaction time: fast.
- ▶ We recommend using an overvoltage protection device when using solar panels.

### 5.6 Wire assignment of connection cable

The electrical connection to the data collector/electronic controls is made via a factory-assembled connection cable with M9 subminiature plug connector (cable socket) and open wire ends (accessories). The connection cable is used both for power supply and data transmission.

For detailed information on the connection, see Chapters 5.7 to 5.11.

Fig. 9: Wire assignment of OTT RLS 500 (HF) connection cable.

**Remark:** The connection cable has a cable shield that is shortened to the cable sheath at the factory during stripping. The cable shield must not be connected to earth/ground when installing the OTT RLS 500 (HF)!

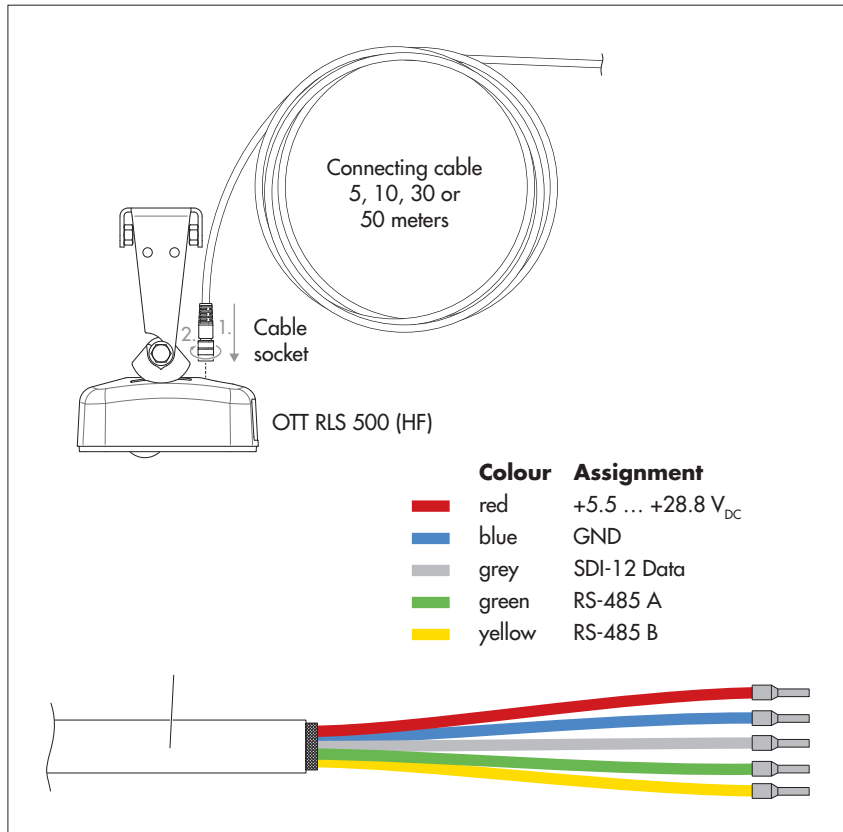

The connection cable can be extended if necessary. Use a suitable junction box for this purpose. The maximum cable length for the RS-485 interface is 1000 m; for the SDI-12 interface 200 m (point-to-point connection)! Recommended cable type for the RS-485 interface: twisted pair cable (twisted pair wires); shielded version. The wires intended for the power supply can, but do not have to be twisted-pair. Recommended cable type for the SDI-12 interface: unshielded low voltage cable.

Usable wire cross-sections

- ▶ up to 500 m · 1.650 ft cable length: 2 x 2 x 0.5 mm (41 Ohm/1000 m)
- ▶ 500 to 1000 m · 1.650 to 3.300 ft cable length: 2 x 2 x 0.75 mm<sup>2</sup> (27 Ohm/1000 m)



**Please note:**

- ▶ If the connection cable needs to be shortened: Cut off the cable shield and the white and green wires directly on the cable sheath. Fit additional cores with wire end ferrules.
- ▶ The cable shield must not be connected to earth/ground when installing the OTT RLS 500 (HF)!

**5.7 Connecting the OTT RLS 500 (HF) to any datalogger using an SDI-12 interface**

- Connect the OTT RLS 500 (HF) to an SDI-12 input of the datalogger. To do so, follow the operating instruction of the datalogger. Refer to Fig. 4 for the connection assignment of the OTT RLS 500 (HF); wires used: red, blue, and grey. The maximum total cable length is 200 m · 656 ft (point-to-point connection).

Fig. 10: Wires used when SDI-12 interface is used.

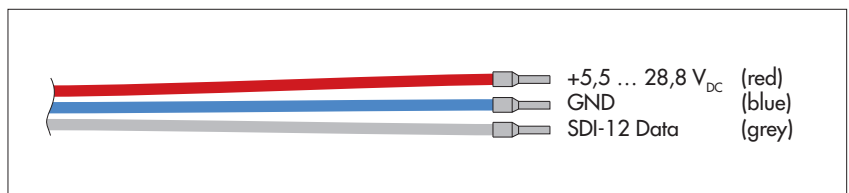

- **Remark:** In an SDI-12 bus, the supply voltage (12 volt line) is 12 volts according to the standard, max. 16 volts. Take this into account if there are other sensors in the SDI-12 bus in addition to the OTT RLS 500 (HF).

For detailed information on connecting to OTT/Sutron dataloggers, see Chapters 5.9 to 5.11.

For the SDI-12 commands and responses that can be used with the OTT RLS 500 (HF), see Chapter 7, *SDI-12 commands and responses*.

## 5.8 Connecting the OTT RLS 500 (HF) to any datalogger/electronic control using an RS-485 interface

- Connect the OTT RLS 500 (HF) to an RS-485 input of the datalogger/an electronic control. To do so, follow the operating instruction of the datalogger/electronic control. Refer to Fig. 5 for the connection assignment of the OTT RLS 500 (HF); wires used: red, blue, green and yellow. The maximum total cable length is 1000 m · 3281 ft. Required wire cross-sections, see Chapter 5.4.

Fig. 11: Wires used when RS-485 interface is used.

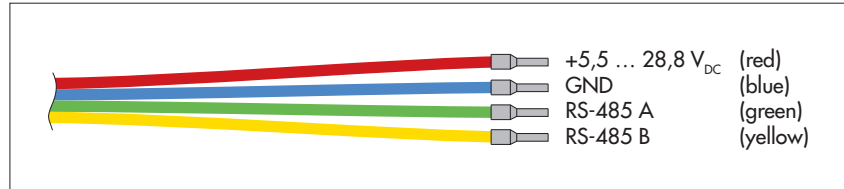

- **Note on using the physical RS-485 interface:**  
Depending on the device variant, the SDI-12 or Modbus (RTU) transmission protocol is available at the RS-485 interface. The RS-485 interface in combination with the SDI-12 protocol is intended and tested for use with OTT and Sutron dataloggers! OTT HydroMet cannot provide a functional guarantee if you connect the OTT RLS 500 (HF) to the data collector of a third-party manufacturer via the RS-485 interface (SDI-12 protocol).

For detailed information on connecting to OTT/Sutron dataloggers, see Chapters 5.9 to 5.11.

For the SDI-12 commands and responses that can be used with the OTT RLS 500 (HF), see Chapter 7, *SDI-12 commands and responses*; information on the Modbus (RTU) transmission in Chapter 8, *RS-485 Interface with Modbus protocol (RTU)*.

## 5.9 Connecting the OTT RLS 500 (HF) to the IP datalogger OTT netDL using an SDI-12 or RS-485 interface

**Variante A:** Connecting the OTT RLS 500 (HF) using an SDI-12 interface (protocol and physical interface: SDI-12). The maximum cable length is 200 m (point-to-point connection)!

- Connect the OTT RLS 500 (HF) to the IP datalogger OTT netDL as shown in Fig. 12 (right). Also follow the operating instructions of the OTT netDL.

**Variante B:** Connecting the OTT RLS 500 (HF) using a physical RS-485 interface (SDI-12 protocol via physical RS-485 interface). The maximum cable length is 1000 m! Required wire cross section, see Chapter 5.4.

- Connect the OTT RLS 500 (HF) to the IP datalogger OTT netDL as shown in Fig. 12 (left). Also follow the operating instructions of the OTT netDL.

Fig. 12: Connecting the OTT RLS 500 (HF) to an OTT netDL using the RS-485 interface (SDI-12 protocol; left) or using the SDI-12 interface (right).

The letters above the screw terminal strips identify the connectivity options available on the OTT netDL.

The other (not used) wires of the connection cable are not shown.

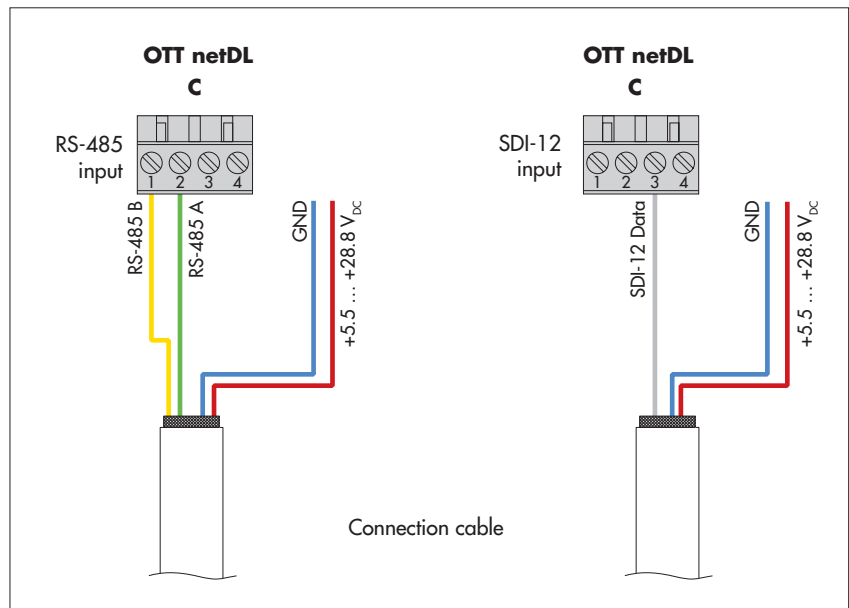

- Configure the OTT netDL IP datalogger as described in the operating instructions of the device and in the online help of the "OTT datalogger Operating Programm".

## 5.10 Connecting the OTT RLS 500 (HF) to the Sutron XLINK 100/500 datalogger using an SDI-12- or RS-485 interface

**Variant A:** Connecting the OTT RLS 500 (HF) using an SDI-12 interface (protocol and physical interface: SDI-12). The maximum cable length is 200 m (point-to-point connection)!

- Connect the OTT RLS 500 (HF) to the Sutron XLINK 100/500 datalogger as shown in Fig 13 (right). Also follow the operating instructions of the Sutron XLINK 100/500.

**Variant B:** Connect the OTT RLS 500 (HF) using a physical RS-485 interface (SDI-12 or Modbus protocol via physical RS-485 interface). The maximum cable length is 1000 m! Required wire cross section, see Chapter 5.4.

- Connect the OTT RLS 500 (HF) to the Sutron XLINK 100/500 datalogger as shown in Fig. 13 (left). Also follow the operating instructions of the Sutron XLINK 100/500.

Fig. 13: Connecting the OTT RLS 500 (HF) to a Sutron XLINK 100/500 using the RS-485 interface (SDI-12 or Modbus-protocol; left) or using the SDI-12 interface (right).

The connection of the power supply of the RS-485 interface to a Sutron XLINK 500 can be made in two ways.

The other (not used) wires of the connection cable are not shown.

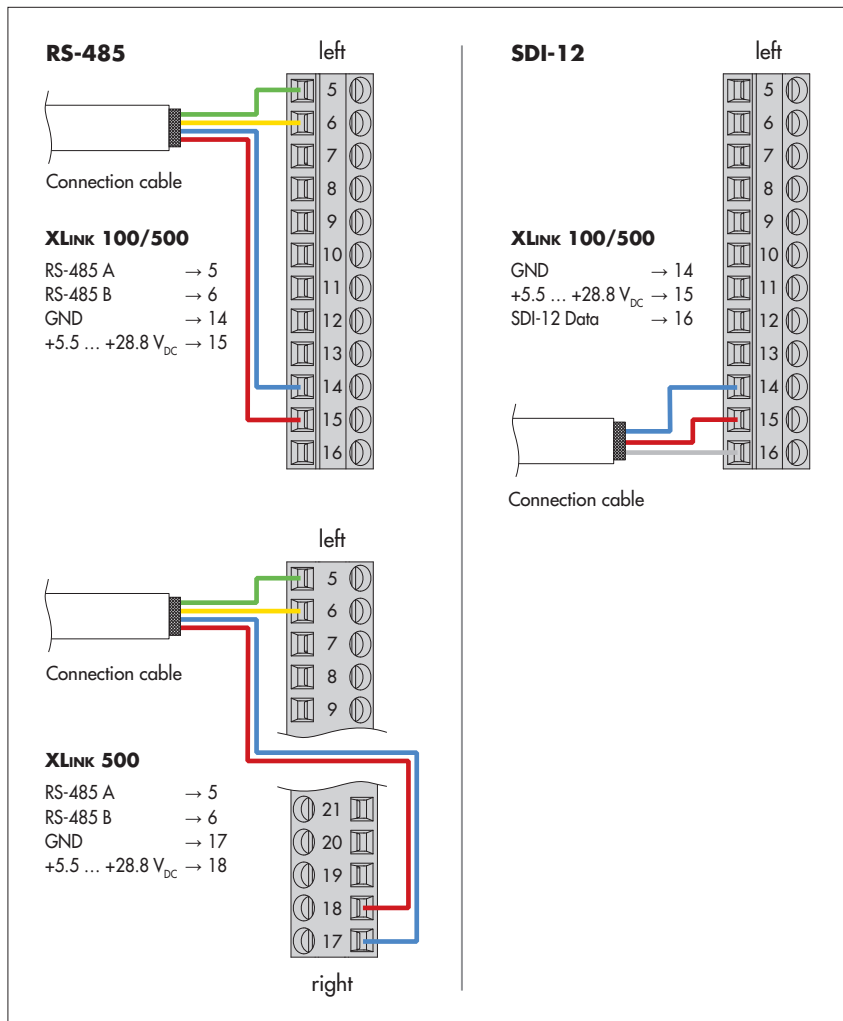

- Configure the Sutron XLINK 100/500 datalogger as described in the operating instructions of the device.

## 5.11 Connecting the OTT RLS 500 (HF) to the Sutron SATLINK 3 datalogger using an SDI-12- or RS-485 interface

**Variante A:** Connecting the OTT RLS 500 (HF) using an SDI-12 interface (protocol and physical interface: SDI-12). The maximum cable length is 200 m (point-to-point connection)!

- Connect the OTT RLS 500 (HF) to the Sutron SATLINK 3 satellite transmitter as shown in Fig. 14 (right). Also follow the operating instructions of the Sutron SATLINK 3.

**Variante B:** Connecting the OTT RLS 500 (HF) using a physical RS-485 interface (SDI-12 protocol or Modbus protocol via physical RS-485 interface). The maximum cable length is 1000 m! Required wire cross section, see Chapter 5.4.

- Connect the OTT RLS 500 (HF) to the Sutron SATLINK 3 satellite transmitter as shown in Fig. 14 (left). Also follow the operating instructions of the Sutron SATLINK 3.

Fig. 14: Connecting the OTT RLS 500 (HF) to the Sutron SATLINK 3 via RS-485 interface (SDI-12- or Modbus-protocol; left) or via SDI-12-interface (right).

The other (not used) wires of the connection cable are not shown.

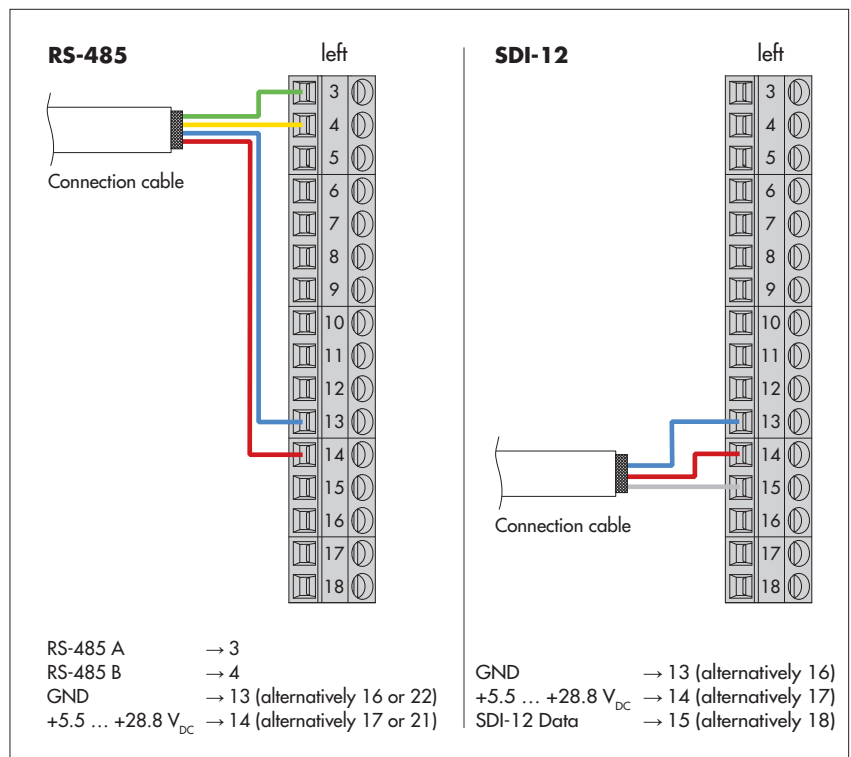

- Configure the Sutron SATLINK 3 satellite transmitter as described in the operating instructions of the device.

## 6 Configuring/testing the OTT RLS 500 (HF)

The OTT RLS 500 (HF) is immediately ready for operation with the standard configuration provided by factory settings. In this case, the radar sensor operates – depending on the variant code ordered (see Chapter 2) with the factory settings (see Chapter 7).

If required, you can make various settings and enter operating parameters after the installation:

- ▶ Units
- ▶ Sensor orientation during installation
- ▶ Measurement mode "level" or "depth"
- ▶ Averaging time
- ▶ Measurement type (single measurement or continuous measurement)
- ▶ Offset value for level/depth measurement
- ▶ Reference value for level/depth measurement
- ▶ Presetting metric or imperial
- ▶ Error indicator
- ▶ Limit value for distance measurement
- ▶ Reset radar sensor
- ▶ Calculation method discharge measurement
- ▶ Rating table and exponential formula for discharge measurement
- ▶ Modbus (RTU) communication parameters
- ▶ OTT RLS 500 HF: sampling rate of distance measurement

This configuration is carried out via the "OTT USB/SDI-12 Adapter" together with the PC Software "OTT SDI-12 Interface"; optionally via the SDI-12- or RS-485-interface. In addition, it is possible to store the sensor orientation, to carry out a control measurement or a system test. In the event of an error, various meta data can be queried for closer analysis.

For this purpose, the radar sensor must be temporarily connected to a PC via the interface converter.

The PC Software automatically detects the connected OTT RLS 500 (HF) and conveniently provides the SDI-12 commands available for the configuration as buttons. You find an overview of these SDI-12 commands in Chapter 7.1.

Alternatively, the configuration can be changed via the "SDI-12 transparent mode" of a datalogger (please observe operating instructions of the datalogger). If the radar sensor is already in "continuous measurement" mode, the settings can also be made via the Modbus configuration registers; see Chapter 8.5.

- **Remark:** For more information on the OTT USB/SDI-12 Adapter, please refer to the "Operating instructions OTT USB/SDI-12 Adapter" and "Online help OTT SDI-12 Interface Software"!
- ! **Please note:** Connecting the OTT RLS 500 (HF) to an OTT SensorLink 1000 compact datalogger overwrites all previous settings/operating parameters in the OTT RLS 500 (HF). In this application, configuration is carried out using the software "LinkComm" (operating software) of OTT HydroMet. Further information → see "Operating instructions compact datalogger OTT SensorLink 1000".



Fig. 15: Changing the factory configuration of an OTT RLS 500 (HF) via SDI-12 commands using the "OTT USB/SDI-12 adapter".

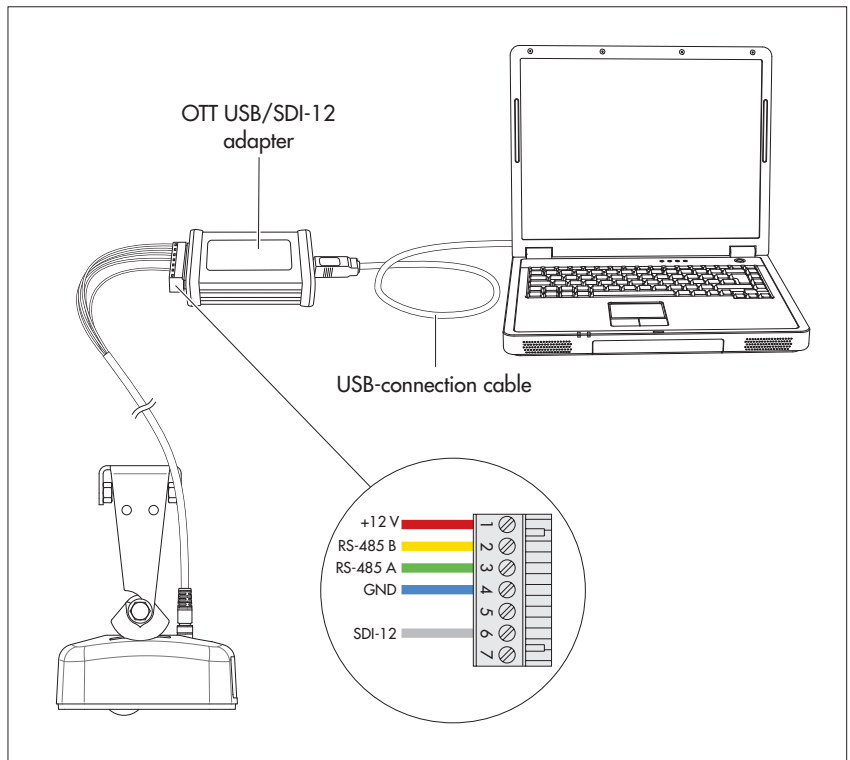

## 7 SDI-12 commands and responses

Communication with the OTT RLS 500 (HF) is carried out either via the physical SDI-12 interface or via the RS-485 interface via the SDI-12 transmission protocol. This technical documentation contains a detailed description of the SDI-12 commands implemented in the SDI-12 transmission protocol.

Further information on the SDI-12 standard can be found in the publication "SDI-12; A Serial-Digital Interface Standard for Microprocessor-Based Sensors; Version 1.4" (see website "www.sdi-12.org").

All extended, manufacturer-specific SDI-12 commands of the OTT RLS 500 (HF) start with an "X". With these commands, it is possible to configure the OTT RLS 500 (HF), for example via the "SDI-12 transparent mode" of a datalogger or with the OTT USB/SDI-12 adapter (accessory).

### Conventions applicable to measured value formats

**p** – Sign (+,-; if it is omitted during input, the OTT RLS 500 (HF) automatically adds a "+")

**b** – Number (ahead of the decimal point)

**e** – Number (after the decimal point)

### 7.1 Overview of SDI-12 commands

#### Standard commands

- ▶ **a!** Confirmation active
- ▶ **aI!** Send identification
- ▶ **aAb!** Change sensor address
- ▶ **?!** Query sensor address; factory setting: 0
- ▶ **aV!** Start system test
- ▶ **aM!** Start measurement
- ▶ **aM1!** Start measurement including statistical values
- ▶ **aMC!** Start measurement and request CRC <sup>1)</sup>
- ▶ **aMC1!** Start measurement including statistical values and request CRC <sup>1)</sup>
- ▶ **aC!** Start concurrent measurement <sup>2)</sup>
- ▶ **aC1!** Start concurrent measurement <sup>2)</sup> including statistical values
- ▶ **aCC!** Start concurrent measurement <sup>2)</sup> and request CRC <sup>1)</sup>
- ▶ **aCC1!** Start concurrent measurement <sup>2)</sup> including statistical values and request CRC <sup>1)</sup>
- ▶ **aM3!** Request metadata of last measurement
- ▶ **aMC3!** Request metadata and CRC <sup>1)</sup> of last measurement
- ▶ **aC3!** Request metadata of last measurement in concurrent mode
- ▶ **aCC3!** Request metadata and CRC <sup>1)</sup> of last measurement in concurrent mode
- ▶ **aR0!** Query data for continuous measurements
- ▶ **aR1!** Query data for continuous measurements including statistical values
- ▶ **aRC0!** Query data for continuous measurements including CRC <sup>1)</sup>
- ▶ **aRC1!** Query data for continuous measurements including statistical values and CRC <sup>1)</sup>
- ▶ **aR3!** Query meta data of last measurement for continuous measurements
- ▶ **aRC3!** Query meta data of last measurement for continuous measurements including CRC <sup>1)</sup>
- ▶ **aHA!** Start "High Volume ASCII" measurement including statistical values and request CRC <sup>1)</sup>
- ▶ **aHB!** Start "High Volume Binary" measurement including statistical values and request CRC <sup>1)</sup>
- ▶ **aD0!** Send data to **aM!**; **aM1!**; **aM3!**; **aMC!**; **aMC1!**; **aMC3!**; **aC!**; **aC1!**; **aC3!**; **aCC!**; **aCC1!**; **aCC3!**; **aHA!**; **aV!**
- ▶ **aD1!** Send data to **aM1!**; **aM3!**; **aMC1!**; **aMC3!**; **aC1!**; **aC3!**; **aCC1!**; **aCC3!**; **aHA!**; **aV!**
- ▶ **aD3!** Send data to **aM1!**; **aM3!**; **aMC1!**; **aMC3!**; **aC1!**; **aC3!**; **aCC1!**; **aCC3!**; **aV!**
- ▶ **aDB0!** Send data after **aHB!**
- ▶ **aDB1!** Send data after **aHB!**

<sup>1)</sup> Cyclic Redundancy Check

<sup>2)</sup> simultaneous measurement with multiple sensors on one bus line

## Measured value overview standard commands<sup>1)</sup>

|  | metric units  |                     | imperial units |                      |
|--|---|---------------------|----------------|----------------------|
| ▶ Send data (D0) after <b>aM!</b> command  |   |                     |                |                      |
| <value1> water level   | pbbb.eee  | [m]                 | pbbb.eee       | [ft]                 |
| <value2> quality indicator; see below  | +b  | [1]                 | +b             | [1]                  |
| <value3> device status; see below  | +bbb  | [1]                 | +bbb           | [1]                  |
| <value4> discharge <sup>2)</sup>   | pbbb.eee  | [m <sup>3</sup> /s] | pbbbbbb.ee     | [ft <sup>3</sup> /s] |
| ▶ Send data (D0, D1, D2) after <b>aM1!</b> command   |   |                     |                |                      |
| <value1> last single measured value of water level over the averaging period                 | pbbb.eee  | [m]                 | pbbb.eee       | [ft]                 |
| <value2> mean of the relative signal amplitude of the radar signal over the averaging period | +bb.ee  | [dB]                | +bb.ee         | [dB]                 |
| <value3> mean of measured values of water level over the averaging period                    | pbbb.eee  | [m]                 | pbbb.eee       | [ft]                 |
| <value4> minimum of measured values of water level within the averaging time                 | pbbb.eee  | [m]                 | pbbb.eee       | [ft]                 |
| <value5> maximum of measured values of water level within the averaging time                 | pbbb.eee  | [m]                 | pbbb.eee       | [ft]                 |
| <value6> median of measured values of water level over the averaging period                  | pbbb.eee  | [m]                 | pbbb.eee       | [ft]                 |
| <value7> standard deviation of measured values of water level over the averaging period      | pbbb.eee  | [m]                 | pbbb.eee       | [ft]                 |
| <value8> device status; see below  |   |                     |                |                      |
| ▶ Send data (D0, D1, D2) after <b>aM3!</b> command   |   |                     |                |                      |
| <value1> – relative humidity in the sensor housing   | pbb.ee  | [% rH]              | pbb.ee         | [% rH]               |
| <value2> – dew point in the sensor housing   | pbb.ee  | [°C]                | pbb.ee         | [°C]                 |
| <value3> – current sensor position X-axis <sup>4)</sup>                                      | pbbb  | [°]                 | pbbb           | [°]                  |
| <value4> – current sensor position Y-axis <sup>4)</sup>                                      | pbbb  | [°]                 | pbbb           | [°]                  |
| <value5> – water level over averaging time   | pbbb.eee  | [m]                 | pbbb.eee       | [ft]                 |
| <value6> – temperature in the sensor housing   | pbb.ee  | [°C]                | pbb.ee         | [°C]                 |
| <value7> – mean of relative signal amplitude of the radar signal over the averaging period   | +bb.ee  | [dB]                | +bb.ee         | [dB]                 |
| <value8> – number of valid individual measured values within the averaging time              | +bbb  | [1]                 | +bbb           | [1]                  |
| <value9> – device status; see below  |   |                     |                |                      |
| ▶ Quality indicator  |   |                     |                |                      |
| +0   | → no radar signal   |                     |                |                      |
| +1   | → weak radar signal   |                     |                |                      |
| +2   | → medium radar signal   |                     |                |                      |
| +3   | → strong radar signal   |                     |                |                      |
| ▶ Device status <sup>3)</sup>  |   |                     |                |                      |
| +0   | → no error occurred   |                     |                |                      |
| +1   | → system reset – status flag is set when connecting the operating voltage/upon unexpected reset; deletion after status read out   |                     |                |                      |
| +2   | → distance value not compensated  |                     |                |                      |
| +4   | → measured value of water level is too low or measured value of depth to water too high   |                     |                |                      |
| +8   | → sensor position has changed (deviation from installation ↔ current ≥ 5°) <sup>5)</sup>  |                     |                |                      |
| +16  | → radar sensor is not pointing downwards  |                     |                |                      |
| +32  | → radar sensor was reset to factory settings due to internal system error (including potential flow settings)   |                     |                |                      |
| +64  | → relative humidity in the probe housing was/is above limit value (≥ 90 % rH); error message is persistent, can only be deleted by system reset or brief interruption of the operating voltage! |                     |                |                      |

<sup>1)</sup> with factory settings

<sup>2)</sup> optional with activated flow calculation; extended command **aXDC<value>!**

<sup>3)</sup> if several errors/events occur simultaneously, the OTT RLS 500 (HF) sums up the status values. Example: +80 → radar sensor is pointing upwards (+16) + relative humidity in the probe housing was/is above limit value (+64); values ≥ +128: exclusively for internal service purposes

<sup>4)</sup> value range 0 ... ±90°; 0° → optimal downward alignment, definition of X-/Y-axes and direction of rotation (positive/negative values); see Annex B

<sup>5)</sup> intentionally change the sensor position (e.g. new installation): → First reset the radar sensor to the factory setting with the command **aXSF!**

## Meta data commands

|                                       |   |                                    |
|---------------------------------------|---|------------------------------------|
| ▶ aIM!                                | Determine response to the corresponding command                               | aM! (does not start a measurement) |
| aIM1!                                 |   | ... aM1!                           |
| aIM3!                                 |   | ... aM3!                           |
| aIMC!                                 |   | ... aMC!                           |
| aIMC1!                                |   | ... aMC1!                          |
| aIMC3!                                |   | ... aMC3!                          |
| aIC!                                  |   | ... aC!                            |
| aIC1!                                 |   | ... aC1!                           |
| aIC3!                                 |   | ... aC3!                           |
| aICC!                                 |   | ... aCC!                           |
| aICC1!                                |   | ... aCC1!                          |
| aICC3!                                |   | ... aCC3!                          |
| aIHA!                                 |   | ... aHA!                           |
| aIHB!                                 |   | ... aHB!                           |
| aIV!                                  |   | ... aV!                            |
| ▶ aIM_001! ... aIM_003! <sup>1)</sup> | Query meta data for measured value 1 to 3 <sup>1)</sup> ; value in aD0! after | aM!                                |
| aIM1_001! ... aIM1_008!               | Query meta data for measured value 1 to 8; value in aD0! ... aD2! after       | aM1!                               |
| aIM3_001! ... aIM3_009!               | Query meta data for measured value 1 to 9; value in aD0! ... aD2! after       | aM3!                               |
| aIMC_001! ... aIMC_003! <sup>1)</sup> |   | ... aMC!                           |
| aIMC1_001! ... aIMC1_008!             |   | ... aMC1!                          |
| aIMC3_001! ... aIMC3_009!             |   | ... aMC3!                          |
| aIC_001! ... aIC_003! <sup>1)</sup>   |   | ... aC!                            |
| aIC1_001! ... aIC1_008!               |   | ... aC1!                           |
| aIC3_001! ... aIC3_009!               |   | ... aC3!                           |
| aICC_001! ... aICC_003! <sup>1)</sup> |   | ... aCC!                           |
| aICC1_001! ... aICC1_008!             |   | ... aCC1!                          |
| aICC3_001! ... aICC3_009!             |   | ... aCC3!                          |
| aIHA_001! ... aIHA_017!               | Query meta data for measured value 1 to 17; value in aD0!, aD1! after         | ... aHA!                           |
| aIHB_001! ... aIHB_017!               | Query meta data for measured value 1 to 17; value in aDB0!, aDB1! after       | ... aHB!                           |
| aIV_001! ... aIV_009!                 | Query meta data for measured value 1 to 9; value in aD0! ... aD2! after       | ... aV!                            |

<sup>1)</sup> 4 with activated flow calculation

## Advanced commands (manufacturer-specific)

- ▶ aXSU<value>! Set unit of water level measurement  
aXSU! Read unit of water level measurement  
factory setting: +0 → m (presetting metric); +2 → ft (presetting imperial)
- ▶ aXSD<value>! Set unit of discharge values  
aXSD! Read unit of discharge values  
factory setting: +0 → m<sup>3</sup>/s (presetting metric); +2 → ft<sup>3</sup>/s (presetting imperial)
- ▶ aXXO!  
aD0! Determine and save sensor orientation during installation  
Read sensor orientation during installation
- ▶ aXAA<value>! Set measurement mode "level-" or "depth"  
aXAA! Read measurement mode  
factory setting: +1 → measurement mode "level"
- ▶ aXXM<value>! Set averaging time  
aXXM! Read averaging time  
factory setting: +3 → 3 seconds

- ▶ **aXXC<value>!** Set measurement type  
**aXXC!** Read measurement type  
factory setting: +0 → measurement type "One measurement interval"
  
- ▶ **aXAB<value>!** Set offset value for level/depth measurements  
**aXAB!** Read offset value  
factory setting: +0.000 m
  
- ▶ **aXAC<value>!** Set reference value for level/depth measurements  
**aXAC!** Read reference value  
factory setting: +0.000 m
  
- ▶ **aXSR<value>!** Reset factory settings for units (metric or imperial)  
**aXSR!** Read factory settings for units (metric or imperial)  
factory setting: depending on the ordered variant code
  
- ▶ **aXSF!** Reset radar sensor to factory settings without communication settings  
**aXSF+1!** Reset radar sensor to factory settings including communication settings
  
- ▶ **aXDC<value>!** Set calculation method for discharge measurement  
**aXDC!** Read calculation method for discharge measurement  
factory setting: +0 → discharge measurement "deactivated"
  
- ▶ **aXDA<value1><value2>!** Create table entry rating table (calculation method: rating table)
- ▶ **aXDA<value1><value2><value3>!** Enter coefficients for discharge measurement (exponential formula)
  
- ▶ **aXDR<value>!** Read table entry rating table (calculation method: rating table)  
**aXDR!** Read number of entries in the rating table (calculation method: rating table)  
**aXDR!** Read coefficients for discharge measurement (calculation method: exponential formula)
  
- ▶ **aXDD<value>!** Delete table entry rating table  
**aXDD+9999!** Delete rating table completely
  
- ▶ **aXSI<value>!** Set error indicator for incorrect distance measurement  
**aXSI!** Read error indicator for incorrect distance measurement  
factory setting: +9999.999 m
  
- ▶ **aXAD<value>!** Set limit value for distance measurement  
**aXAD!** Read limit value for distance measurement  
factory setting: +9000.000 (depth measurement), -9000.000 (level measurement)
  
- ▶ **aXCA<value>!** RS-485 interface: set Modbus (RTU) address  
**aXCA!** RS-485 interface: read Modbus (RTU) address  
factory setting: +1
  
- ▶ **aXCB<value>!** RS-485 interface: Modbus (RTU) set transmission speed (baud rate)  
**aXCB!** RS-485 interface: Modbus (RTU) read transmission speed (baud rate)  
factory setting: +0 → 9 600 bit/s
  
- ▶ **aXCP<value>!** RS-485 interface: Modbus (RTU) set parity  
**aXCP!** RS-485 interface: Modbus (RTU) read parity  
factory setting: +3 → even, 1 Stopbit
  
- ▶ **aXXD<value>!** for device variant OTT RLS 500 HF: set sampling rate of distance measurement  
**aXXD!** for device variant OTT RLS 500 HF: read sampling range of distance measurement  
factory setting: +1 → 2 Hz

## 7.2 Standard commands

| Command | Response  | Description   |
|---------|---|---|
| a!      | a<CR><LF>   | Confirmation active<br>a – sensor address; factory setting: 0   |
| aI!     | allccccccmmmmmmvvv...<br>...xxxxxxxxxxxxx<CR><LF> | Send identification<br>a – sensor address<br>ll – SDI-12 protocol version<br>ccccccc – manufacturer's identification (company name)<br>mmmmmm – sensor identification<br>vvv – sensor version (here firmware version)<br>xxxxxxxxxxxxx – additional identification (in this case serial number; max. 13 characters)<br>OTT RLS 500 (HF) response: 0140TTHYDRORLS500100...<br>...xxxxxxxxxxxxx |
| aAb!    | b<CR><LF>   | Change sensor address<br>a – old sensor address<br>b – new sensor address   |
| ?!      | a<CR><LF>   | Query sensor address<br>a – sensor address  |
| aV!     | atttn<CR><LF>                                     | Perform system test<br>a – sensor address<br>ttt – time in seconds until the sensor provides the result of the system test<br>response OTT RLS 500 (HF): 000<br>n – number of measured values<br>response OTT RLS 500 (HF): 9   |
| aD0!    | a<value1><value2><value3>...<br>...<CR><LF>       | Send data (after aV!)<br>a – sensor address<br><value1> – relative humidity in the probe housing<br>measured value format: pbb.ee [% rH]<br><value2> – dew point in the probe housing <sup>1)</sup><br>measured value format: pbb.ee [°C]<br><value3> – current sensor orientation X-axis <sup>2)</sup><br>measured value format pbb [°]  |
| aD1!    | a<value4><value5><value6>...<br>...<CR><LF>       | Send data (after aV!)<br>a – sensor address<br><value4> – current sensor orientation Y-axis <sup>2)</sup><br>measured value format pbb [°]<br><value5> – mean value of water level over the averaging period<br>measured value format pbb.eee [m]<br><value6> – temperature in probe housing<br>measured value format pbb.ee [°C]   |
| aD2!    | a<value7><value8><value9>...<br>...<CR><LF>       | Send data (after aV!)<br>a – sensor address<br><value7> – mean value of the relative signal amplitude of the radar signal over the averaging period<br>measured value format +bb.ee [dB]<br><value8> – number of valid single measurements within the averaging time<br>measured value format +bbb [1]  |

(Continuation see next page)

<sup>1)</sup> The dew point is calculated for output values up to a minimum of -15° Celsius; if no calculation is possible (e.g. temperature < 0) → output value: +9999

<sup>2)</sup> Value range 0 ... ±90°; 0° → optimal downward alignment, definition of X-/Y-axes and direction of rotation (positive/negative values): see Annex B

| Command    | Response  | Description  |
|------------|---|--|
|            |   | (Continuation from previous page)  |
|            |   | <p><b>&lt;value9&gt;</b> – Device status</p> <ul style="list-style-type: none"> <li>+0 → no error occurred</li> <li>+1 → system reset – status flag is set when connecting the operating voltage/upon unexpected reset; deletion after status read out</li> <li>+2 → distance value not compensated</li> <li>+4 → measured value of water level is too low or measured value of depth to water too high</li> <li>+8 → sensor orientation change (deviation since installation ↔ currently <math>\geq 5^\circ</math>)<sup>1)</sup></li> <li>+16 → radar sensor is not pointing downwards</li> <li>+32 → radar sensor was reset to factory settings due to internal system error (including potential flow settings)</li> <li>+64 → relative humidity in the probe housing was/is above limit value (<math>\geq 90\%</math> rH); error message is persistent, can only be deleted by system reset or brief interruption of the operating voltage!</li> </ul> |
|            |   | <p><b>Note:</b></p> <ul style="list-style-type: none"> <li>– If several errors/events occur simultaneously, the OTT RLS 500 (HF) sums up the status values. Example: +80 → radar sensor is pointing upwards (+16) + relative humidity in the probe housing was/is above limit value (+64);</li> <li>– Values <math>\geq +128</math>: exclusively for internal service purposes</li> </ul>  |
| <b>aM!</b> | <p><b>atttn&lt;CR&gt;&lt;LF&gt;</b><br/>and after 0/2 ... 61 seconds<br/><b>a&lt;CR&gt;&lt;LF&gt;</b></p> | <p>Start measurement – including device status</p> <ul style="list-style-type: none"> <li><b>a</b> – sensor address</li> <li><b>ttt</b> – time in seconds until the sensor provides the measurement result<br/>response OTT RLS 500 (HF): 0/2 ... 61 sec.<sup>2)</sup></li> <li><b>n</b> – number of measured values<br/>response OTT RLS 500 (HF): 3 (only level measurement) or 4 (with discharge calculation)</li> </ul>  |

<sup>1)</sup> change sensor orientation intended (e.g. new installation); → first reset radar sensor to factory settings with command **axSF!**

<sup>2)</sup> depending on the set averaging time; advanced command **axXM<value>**!

In the measurement type "continuous measurement" the time is always 0 seconds (with the exception of the first interval after the start)!

| Command | Response  | Description  |
|---------|---|--|
| aD0!    | a<value1><value2><value3>...<br>...<value4><CR><LF>       | Send data (after aM!)<br>a – Sensor address<br><value1> – mean value of water level over the averaging period measured value formats <sup>1)</sup> :<br>pbbb.eee [m]<br>pbbbb.e [cm]<br>pbbbb [mm]<br>pbbb.eee [ft]<br>pbbb.eee [inch]<br><value2> – quality indicator of level measurement<br>+0 → no radar signal<br>+1 → weak radar signal<br>+2 → medium radar signal<br>+3 → strong radar signal<br><value3> – device status<br>see aD2! after aV!<br><value4> – discharge <sup>3)</sup><br>measured value formats <sup>2)</sup> :<br>pbbb.eee [m <sup>3</sup> /s]<br>pbbbb [l/s]<br>pbbbb.ee [ft <sup>3</sup> /s]<br><br><b>Note:</b> measured value discharge = -9999 → error occurred during calculation or W/Q table is missing; = -9998 → entries in the W/Q table are not sufficient for calculation. |
| aMC!    | attn<CR><LF><br>and after 0/2 ... 61 seconds<br>a<CR><LF> | Start measurement and request CRC (Cyclic Redundancy Check) ; for details see command aM! .<br>The response to the following aD0! command is extended by a CRC value: a<value1><value2><value3>...<br>...<value4><CR><CR><LF>  |
| aC!     | attnn<CR><LF>   | Start concurrent measurement (simultaneous measurement with multiple sensors on one single bus line); for details see command aM! . The number of measured values in the response to this command has two digits: nn = 03 or 04 <sup>3)</sup> .  |
| aCC!    | attnn<CR><LF>   | Start concurrent measurement (simultaneous measurement with multiple sensors on one single bus line) and request CRC (Cyclic Redundancy Check); for details see command aM! . The number of measured values in the response to this command has two digits: nn = 03 or 04 <sup>3)</sup> .<br>The response to the following aD0! command is extended by a CRC value: a<value1><value2><value3>...<br>...<value4><CR><CR><LF>  |
| aR0!    | a<value1><value2><value3>...<br>...<value4><CR><LF>       | The OTT RLS 500 (HF) continually measures the water level and optionally calculates the discharge. This command permits to retrieve measurement results even without the combination of commands aM!/aD0! ; for details see command aD0! after aM! . Requires measurement type "continuous measurement"; extended command aXX<value>!  |

<sup>1) 2)</sup> depending on the set unit; extended command aXSU<value>! <sup>1)</sup>; aXSD<value>! <sup>2)</sup>

<sup>3)</sup> optional with activated discharge calculation; extended command aXDC<value>!



| Command | Response   | Description  |
|---------|--|--|
| aRC0!   | a<value1><value2><value3>...<br>...<value4><CRC><CR><LF>   | The OTT RLS 500 (HF) continuously measures the water level and optionally calculates the discharge and requests a CRC value (Cyclic Redundancy Check). This command permits to retrieve measurement results, even without the combination of commands aM!/aD0! ; for details, see command aD0! after aM!. Requires measurement type "continuous measurement"; extended command aXXC<value>!          |
| aM1!    | atttn<CR><LF><br>and after 0/2 ... 61 seconds<br>a<CR><LF> | Start measurement – including statistical values<br>a – sensor address<br>ttt – time in seconds until the sensor has determined the measurement result<br>response OTT RLS 500 (HF): 0/2 ... 61 sec. <sup>1)</sup><br>n – number of measured values<br>response OTT RLS 500 (HF): 8  |
| aD0!    | a<value1><value2><value3>...<br>...<CR><LF>                | Send data (after aM1!)<br>a – sensor address<br><value1> – last single measured value of water level within the averaging time <sup>2)</sup><br><value2> – mean value of the relative signal amplitude of the radar signal over the averaging period<br>measured value format +bb.ee [dB]<br><value3> – mean of measured values of water level within the averaging time <sup>2) 3)</sup>            |
| aD1!    | a<value4><value5><value6>...<br>...<CR><LF>                | Send data (after aM1!)<br>a – sensor address<br><value4> – minimum of measured values of water level within the averaging time <sup>2) 3)</sup><br><value5> – maximum of measured values of water level within the averaging time <sup>2) 3)</sup><br><value6> – median of measured values of water level within the averaging time <sup>2) 3)</sup>   |
| aD2!    | a<value7><value8><CR><LF>                                  | Send data (after aM1!)<br>a – sensor address<br><value7> – standard deviation of measured values of water level over the averaging period <sup>2) 3)</sup><br><value8> – device status; see aD2! after aV!   |
| aMC1!   | atttn<CR><LF><br>and after 0/2 ... 61 seconds<br>a<CR><LF> | Start measurement and request CRC (Cyclic Redundancy Check); for details, see command aM1!.<br>The response to the following aD0! ... aD2! command is extended by a CRC value:<br>a<valueX><valueX><valueX><CRC><CR><LF>   |
| aC1!    | atttnn<CR><LF>   | Start concurrent measurement (simultaneous measurement with multiple sensors on one single bus line); for details, see command aM1!. The number of measured values in the response to this command has two digits: nn = 08.  |
| aCC1!   | atttnn<CR><LF>   | Start concurrent measurement (simultaneous measurement with multiple sensors on one single bus line) and request CRC (Cyclic Redundancy Check); for details, see command aM1!. The number of measured values in the response to this command has two digits: nn = 08. The response to the following aD0! ... aD2! command is extended by a CRC value:<br>a<valueX><valueX><valueX>.....<CRC><CR><LF> |

<sup>1)</sup> depending on the set averaging time; extended command aXXM<value>!

In the measurement type "continuous measurement" the time is always 0 seconds (with the exception of the first interval after the start)!

<sup>2)</sup> for measured value formats, see aD0! after aM! (depending on the set unit)

<sup>3)</sup> determined from 1/2/4/8 ... 60/120/240/480 samplings of a measurement interval (depending on the sampling rate; see commands aXXM! + aXXD!)

| Command | Response   | Description  |
|---------|--|--|
| aR1!    | a<value1><value2><value3>...<br>...<value4><value5><value6>...<br>...<value7><value8><CR><LF>      | The OTT RLS 500 (HF) continuously measures the water level and determines statistical values. This command permits to retrieve measurement results, even without the combination of commands aM1!/aD0! ... aD2! ; for details, see command aD0! ... aD2! after aM1!. Requires measurement type "continuous measurement"; extended command aXXC<value>!   |
| aRC1!   | a<value1><value2><value3>...<br>...<value4><value5><value6>...<br>...<value7><value8><CRC><CR><LF> | The OTT RLS 500 (HF) continuously measures the water level, determines statistical values and requests a CRC value (Cyclic Redundancy Check). This command permits to retrieve measurement results, even without the combination of commands aM1!/aD0! ... aD2! ; for details, see command aD0! ... aD2! after aM1!. Requires measurement type "continuous measurement"; extended command aXXC<value>! |
| aM3!    | atttn<CR><LF><br>and after 0/2 ... 61 seconds<br>a<CR><LF>   | Request meta data of last measurement<br>a – sensor address<br>ttt – time in seconds until the sensor has determined the measurement result<br>response OTT RLS 500 (HF): 0/2 ... 61 sec. <sup>1)</sup><br>n – number of measured values<br>response OTT RLS 500 (HF): 9   |
| aD0!    | a<value1><value2><value3>...<br>...<CR><LF>  | Send data (after aM3!)<br>a – sensor address<br><value1> – relative humidity in the probe housing<br>measured value format pbb.ee [% rH]<br><value2> – dew point in the probe housing<br>measured value format pbb.ee [°C]<br><value3> – current sensor orientation X-axis <sup>2)</sup><br>measured value format pbb [°]  |
| aD1!    | a<value4><value5><value6>...<br>...<CR><LF>  | Send data (after aM3!)<br>a – sensor address<br><value4> – current sensor orientation Y-axis <sup>2)</sup><br>measured value format pbb [°]<br><value5> – water level over the averaging period<br>measured value format pbb.eee [m]<br><value6> – temperature in the probe housing<br>measured value format pbb.ee [°C]   |
| aD2!    | a<value7><value8><value9>...<br>...<CR><LF>  | Send data (after aM3!)<br>a – sensor address<br><value7> – mean value of the relative signal amplitude of the radar signal over the averaging period<br>measured value format +bb.ee [dB]<br><value8> – number of valid single measurements within the averaging time<br>measured value format +bbb [1]<br><value9> – device status; see aD2! after aV!  |
| aMC3!   | atttn<CR><LF><br>and after 0/2 ... 61 seconds<br>a<CR><LF>   | Request meta data of last measurement and CRC (Cyclic Redundancy Check); for details, see command aM3!.<br>The response to the following aD0! ... aD2! command is extended by a CRC value:<br>a<valueX><valueX><valueX><CRC><CR><LF>   |

<sup>1)</sup> depending on the set averaging time; extended command aXXM<value>!

In the measurement type "continuous measurement" the time is always 0 seconds (with the exception of the first interval after the start)!

<sup>2)</sup> Value range 0 ... ±90°; 0° → optimal downward alignment, definition of X-/Y-axes and direction of rotation (positive/negative values): see Annex B

| Command | Response   | Description  |
|---------|--|--|
| aC3!    | atttnn<CR><LF>   | Start concurrent measurement (simultaneous measurement with multiple sensors on one single bus line); for details, see command aM3!. The number of measured values in the response to this command has two digits: nn = 09.  |
| aCC3!   | atttnn<CR><LF>   | Start concurrent measurement (simultaneous measurement with multiple sensors on one single bus line) and request CRC (Cyclic Redundancy Check); for details, see command aM3!. The number of measured values in the response to this command has two digits: nn = 09. The response to the following aD0! ... aD2! command is extended by a CRC value:<br>a<valueX><valueX><valueX>.....<CRC><CR><LF>   |
| aR3!    | a<value1><value2><value3>...<br>...<value4><value5><value6>...<br>...<value7><value8><CR><LF>                | The OTT RLS 500 (HF) continuously measures the water level and determines meta data. This command permits to retrieve measurement results, even without the combination of commands aM3!/aD0! ... aD2!; for details, see command aD0! ... aD2! after aM3!. Requires measurement type "continuous measurement"; extended command aXXC<value>!   |
| aRC3!   | a<value1><value2><value3>...<br>...<value4><value5><value6>...<br>...<value7><value8><CRC><CR><LF>           | The OTT RLS 500 (HF) continuously measures the water level, determines meta data and requests a CRC value (Cyclic Redundancy Check). This command permits to retrieve measurement results, even without the combination of commands aM3!/aD0! ... aD2!; for details, see command aD0! ... aD2! after aM3!. Requires measurement type "continuous measurement"; extended command aXXC<value>!   |
| aHA!    | atttnnn<CR><LF>  | Start "High volume" measurement in ASCII format and request CRC (Cyclic Redundancy Check)<br>a           – sensor address<br>ttt       – time in seconds until the sensor has determined the measurement result<br>response OTT RLS 500 (HF): 0/2 ... 61 sec. <sup>1)</sup><br>nnn       – number of measured values<br>response OTT RLS 500 (HF): 17  |
| aD0!    | a<value1><value2><value3>...<br>...<value4><value5><value6>...<br>...<value7><value8>...<br>...<CRC><CR><LF> | Send data (after aHA!)<br>a           – sensor address<br><value1> – last single measured value of the water level within the averaging time <sup>2)</sup><br><value2> – mean value of the relative signal amplitude of the radar signal over the averaging period <sup>3)</sup><br><value3> – mean of measured values of water level over the averaging period <sup>2) 3)</sup><br><value4> – minimum of measured values of water level within the averaging time <sup>2) 3)</sup><br><value5> – maximum of measured values of water level within the averaging time <sup>2) 3)</sup><br><value6> – median of measured value of water level over the averaging period <sup>2) 3)</sup><br><value7> – standard deviation of measured values of water level over the averaging period <sup>2) 3)</sup><br><value8> – number of valid single measurements within the averaging time<br><CRC>     – CRC value |

<sup>1)</sup> depending on the set averaging time; extended command aXXM<value>!

In the measurement type "continuous measurement" the time is always 0 seconds (with the exception of the first interval after the start)!

<sup>2)</sup> for measured value formats, see aD0! after aM! (depending on the set unit)

<sup>3)</sup> determined from 1/2/4/8 ... 60/120/240/480 samplings of a measurement interval (depending on the sampling rate; see commands aXXM! + aXXD!)

| Command | Response   | Description   |
|---------|--|---|
| aD1!    | a<value9><value10><value11>...<br>...<value12><value13><value14>...a<br>...<value15><value16><value17>...<value9><br>...<CRC><CR><LF>                              | Send data (after aHA!)<br>– sensor address<br>– relative humidity in the probe housing<br>measured value format pbb.ee [% rH]<br><value10> – dew point in the probe housing <sup>1)</sup><br><value11> – temperature in the probe housing <sup>1)</sup><br><value12> – current sensor orientation X-axis <sup>2)</sup><br>measured value format pbb [°]<br><value13> – current sensor orientation Y-axis <sup>2)</sup><br>measured value format pbb [°]<br><value14> – stored sensor orientation X-axis <sup>2)</sup><br>measured value format pbb [°]<br><value15> – stored sensor orientation Y-axis <sup>2)</sup><br>measured value format pbb [°]<br><value16> – discharge <sup>1)</sup><br><value17> – device status; see aD2! after aV!<br><CRC> – CRC value<br><br><b>Note:</b> measured value discharge = -9999 → error occurred during calculation or W/Q table is missing; = -9998 → entries in the W/Q table are not sufficient for calculation. |
| aHB!    | atttnnn<CR><LF>  | Start "High volume" measurement in binary format and request CRC (Cyclic Redundancy Check)<br>a – sensor address<br>ttt – time in seconds until the sensor has determined the measurement result<br>response OTT RLS 500 (HF): 0/2 ... 61 sec. <sup>1)</sup><br>nnn – number of measured values<br>response OTT RLS 500 (HF): 17  |
| aDB0!   | Binary data header<br>SDI-12 sensor address "0"; packet size<br>60 bytes; data type: 9, IEEE 32-bit floating<br>point numbers with single precision<br>Binary data | Send data (after aHB!)<br>IEEE 32-bit floating point numbers with single precision<br><value1>...<value17> The measured values correspond to the description of aD0! and aD1! after aHA!  |
| aDB1!   | Binary data header<br>SDI-12 sensor address "0"; packet size<br>4 bytes; data type: 4, unsigned 16-bit<br>integer values<br>Binary data                            | Send data (after aHB!)<br>unsigned 16-bit integer values<br><value1> number of valid single measurements within the averaging time<br><value2> device status; see aD2! after aV!  |

<sup>1)</sup> for measured value formats, see aD0! after aM! (depending on the set unit)

<sup>2)</sup> Value range 0 ... ±90°; 0° → optimal downward alignment, definition of X-/Y-axes and direction of rotation (positive/negative values): see Annex B

### 7.3 Meta data commands

| Command                  | Response                  | Description   |
|--------------------------|---------------------------|---|
| aIM!                     | atttn<CR><LF>             | The response is identical to the corresponding measurement command (aM!, aM1!, aM3!, aMC!, aMC1!, ...). These commands did not start a measurement! For a description of the responses, see commands aM!, aM1!, aM3!, aMC!, aMC1!, ... .  |
| aIM1!                    | atttn<CR><LF>             |   |
| aIM3!                    | atttn<CR><LF>             |   |
| aIMC!                    | atttn<CR><LF>             |   |
| aIMC1!                   | atttn<CR><LF>             |   |
| aIMC3!                   | atttn<CR><LF>             |   |
| aIC!                     | atttnn<CR><LF>            |   |
| aIC1!                    | atttnn<CR><LF>            |   |
| aIC3!                    | atttnn<CR><LF>            |   |
| aICC!                    | atttnn<CR><LF>            |   |
| aICC1!                   | atttnn<CR><LF>            |   |
| aICC3!                   | atttnn<CR><LF>            |   |
| aIHA!                    | atttnnn<CR><LF>           |   |
| aIHB!                    | atttnnn<CR><LF>           |   |
| aIV!                     | atttn<CR><LF>             | The response is identical to the corresponding command "Start system test" (aV!). This command does not start a system test! For a description of the response, see command aV! .   |
| aIM_00X! <sup>1)</sup>   | a,<field1>,<field2>,...   | The OTT RLS 500 (HF) sends meta data for the related measured value <valueX> <sup>5)</sup> in the form of three data fields. These commands did not start a measurement! The measured value code (<field1>) and the unit designations (<field2>) correspond to the "SHEF" standard (see "Standard Hydrometeorological Exchange Format (SHEF) – Code Manual" of the "National Weather Service" <sup>6)</sup> .<br><br><b>a</b> – sensor address<br><b>&lt;field1&gt;</b> – measured value code<br>· water level: HA · HB<br>· temperature: TW · TA · TD<br>· humidity: XR<br>· device status: OS<br><b>&lt;field2&gt;</b> – unit<br>· length: M · CM · MM · IN · FT<br>· temperature: DC<br>· humidity: %<br>· discharge: CMS · LS · CFS<br>· angle: DEG<br>· signal amplitude: dB |
| aIM1_00X! <sup>2)</sup>  | ...<field3>;<CRC><CR><LF> |   |
| aIM3_00X! <sup>3)</sup>  |                           |   |
| aIMC_00X! <sup>1)</sup>  |                           |   |
| aIM1C_00X! <sup>2)</sup> |                           |   |
| aIM3C_00X! <sup>3)</sup> |                           |   |
| aIC_00X! <sup>1)</sup>   |                           |   |
| aIC1_00X! <sup>2)</sup>  |                           |   |
| aIC3_00X! <sup>3)</sup>  |                           |   |
| aICC_00X! <sup>1)</sup>  |                           |   |
| aICC1_00X! <sup>2)</sup> |                           |   |
| aICC3_00X! <sup>3)</sup> |                           |   |
| aIHA_00X! <sup>4)</sup>  |                           |   |
| aIHB_00X! <sup>4)</sup>  |                           |   |
| aIV_00X!! <sup>3)</sup>  |                           |   |

<sup>1)</sup> Variable ...X: from 1 to 3 or 4

<sup>2)</sup> Variable ...X: from 1 to 8

<sup>3)</sup> Variable ...X: from 1 to 9

<sup>4)</sup> Variable ...X: from 1 to 17

<sup>5)</sup> Part of the response to the command aD0!, aD1!, aD2! (after aM!, aM1!, aMC!, ...)

<sup>6)</sup> <https://vlab.noaa.gov/web/mdl/shef-information> (K, LS, DEG, dB → no official SHEF Code)

(Continuation of the description, see next page)

| Command | Response | Description                                     |
|---------|----------|---|
|         |          | (Continuation of description of previous pages) |
|         |          | <field3>- textual description                   |
|         |          | Last ring buffer level                          |
|         |          | Mean level                                      |
|         |          | Min. level                                      |
|         |          | Max. level                                      |
|         |          | Median level                                    |
|         |          | Standard deviation level                        |
|         |          | Signal quality indicator                        |
|         |          | Relative signal strength                        |
|         |          | Inside humidity                                 |
|         |          | Inside dew point                                |
|         |          | Inside temperature                              |
|         |          | Current orientation, x-Axis                     |
|         |          | Current orientation, y-Axis                     |
|         |          | Stored orientation, x-Axis                      |
|         |          | Stored orientation, y-Axis                      |
|         |          | Device status                                   |
|         |          | Number of valid averaged distance values        |
|         |          | Level reference value                           |
|         |          | Level offset value                              |
|         |          | Discharge                                       |
|         |          | <CRC> - CRC-value <sup>1)</sup>                 |

<sup>1)</sup> only for aIMC\_00X!, aICC\_00X!, aIMC1\_00X!, aICC1\_00X!, aIMC3\_00X!, aICC3\_00X!

### Examples for meta data commands

0IM! → 00023<CR><LF>

5IV! → 50029<CR><LF>

0IM\_001! → 0, HA, M, Mean level;<CR><LF>

0IM3\_007! → 0, ,dBm, Relative signal strength;<CR><LF>

## 7.4 Advanced SDI-12 commands

| Command   | Response                  | Description   |
|---|---------------------------|---|
| ▶ Set/read the unit of measured water level values                              |                           |   |
| aXSU<value>!  | a<value><CR><LF>          | Set unit  |
| aXSU!   | a<value><CR><LF>          | Read unit   |
|   |                           | a – sensor address  |
|   |                           | <value> – +0: m   |
|   |                           | +1: cm  |
|   |                           | +4: mm  |
|   |                           | +2: ft  |
|   |                           | +3: inch  |
|   |                           | factory setting: m or ft <sup>1)</sup>  |
| ▶ Set/read the unit of measured discharge values                                |                           |   |
| aXSD<value>!  | a<value><CR><LF>          | Set unit  |
| aXSD!   | a<value><CR><LF>          | Read unit   |
|   |                           | a – sensor address  |
|   |                           | <value> – +0: m <sup>3</sup> /s   |
|   |                           | +1: l <sup>3</sup> /s   |
|   |                           | +2: ft <sup>3</sup> /s  |
|   |                           | factory setting: m <sup>3</sup> /s or ft <sup>3</sup> /s <sup>1)</sup>  |
| ▶ Determine and store/read sensor orientation during installation <sup>2)</sup> |                           |   |
| aXXO! <sup>3)</sup>   | atttn<CR><LF>             | Determine and store sensor orientation  |
|   |                           | Description of the response: see command aM!  |
|   |                           | You can use this command to have the radar sensor determine and store the sensor position during installation. In case of an error, the stored value can be checked against the current sensor orientation (command aV!). |
|   |                           | <b>Note:</b> This command starts a subsequent measurement with the set averaging time.  |
| aD0!  | a<value1><value2><CR><LF> | Read sensor orientation   |
|   |                           | a – sensor address  |
|   |                           | <value1> – measured/stored sensor orientation, X-axis   |
|   |                           | <value2> – measured/stored sensor orientation, Y-axis   |
| ▶ Set/read measurement mode   |                           |   |
| aXAA<value>!  | a<value><CR><LF>          | Set measurement mode "level" or "depth"   |
| aXAA!   | a<value><CR><LF>          | Read measurement mode   |
|   |                           | a – sensor address  |
|   |                           | <value> – +0 = measurement mode "depth" measurement <sup>4)</sup>   |
|   |                           | +1 = measurement mode "level" measurement   |
|   |                           | factory setting: +1 → "level" measurement   |

<sup>1)</sup> depending on the ordered variant code

<sup>2)</sup> intended change of sensor orientation (e.g. new installation): → first reset radar sensor to factory setting with command aXSF!

<sup>3)</sup> aXXO! → Character "O"

<sup>4)</sup> "Depth" = distance between antenna (Radom) and water surface

| Command   | Response         | Description   |
|---|------------------|---|
| ▶ Set/read limit value for distance measurement |                  |   |
| aXAD<value>!                                    | a<value><CR><LF> | Set limit value for distance measurement  |
| aXAD!   | a<value><CR><LF> | Read limit value  |
|   |                  | a – sensor address  |
|   |                  | <value> – pbbbb.eee   |
|   |                  | Input/output without leading zero!  |
|   |                  | Value range: –9000.000 ... +9000.000  |
|   |                  | Factory setting: +9000.000 (depth measurement);<br>–9000.000 (level measurement)  |
|   |                  | If the level/depth measurement value falls below/exceeds this limit value, the OTT RLS 500 (HF) outputs the device status +4. The limit value can be used for bottom detection of the water body.   |
|   |                  | <b>Notes:</b>   |
|   |                  | – Changing the measurement mode (aXAA<value>!) resets the value to the factory setting.   |
|   |                  | – The unit/decimal places are identical to the unit set for the water level measured values (aXAA<value>!).   |
| ▶ Set/read averaging time                       |                  |   |
| aXXM<value>!                                    | a<value><CR><LF> | Set averaging time  |
| aXXM!   | a<value><CR><LF> | Read averaging time   |
|   |                  | a – sensor address  |
|   |                  | <value> – +bb   |
|   |                  | Input/output without leading zero!  |
|   |                  | Value range: 1 ... 60 s   |
|   |                  | Factory setting: 3 s  |
|   |                  | <b>Note</b>   |
|   |                  | This command starts a subsequent measurement with the set averaging time  |
| ▶ Set/read measurement type                     |                  |   |
| aXXC<value>!                                    | a<value><CR><LF> | Set measurement type  |
| aXXC!   | a<value><CR><LF> | Read measurement type   |
|   |                  | a – sensor address  |
|   |                  | <value> – +0: single measurement  |
|   |                  | +1: continuous measurement, interval mode   |
|   |                  | +2: continuous measurement, floating mode   |
|   |                  | Factory setting: +0 → measurement type "single measurement"   |
|   |                  | The OTT RLS 500 (HF) samples the water surface by radar beam at least once per second (depending on the device variant/setting). One single sampling takes approx. 100 milliseconds. The radar sensor then calculates an arithmetic mean value from several sampled measured values over the adjustable averaging period. |
|   |                  | – OTT RLS 500: 1 sampling/second (2 Hz).  |
|   |                  | – OTT RLS 500 HF: optionally 2, 4 or 8 sampling(s)/second (2, 4 or 8 Hz; see command aXXD<value>!).   |
|   |                  | The averaging time for both device variants can be set between 1 and 60 seconds.  |
|   |                  | <b>Single measurement:</b> The OTT RLS 500 (HF) is in idle mode by default. An SDI-12 measurement command starts a series of samplings over the set averaging period. This measurement type is available in parallel on the SDI-12- and RS-485 interface.   |



**Command**

**Response**

**Description**

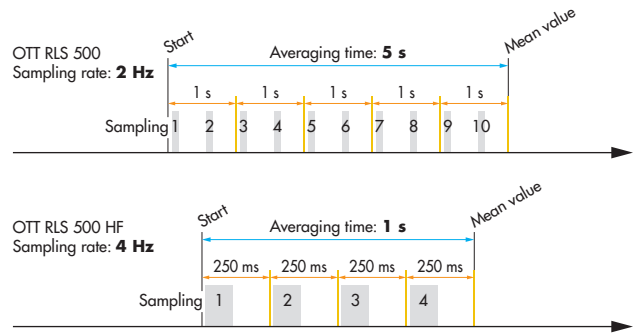

**Continuous measurement, interval mode:**

In interval mode samplings take place continuously one after the other. The OTT RLS 500 (HF) immediately responds to an **aRx!** command with a measured value (with the exception of the first interval after the start). This value is always updated after the averaging time has expired. The response to an **aMx!** command indicates the time left, until the averaging time is expired and an updated value is available.

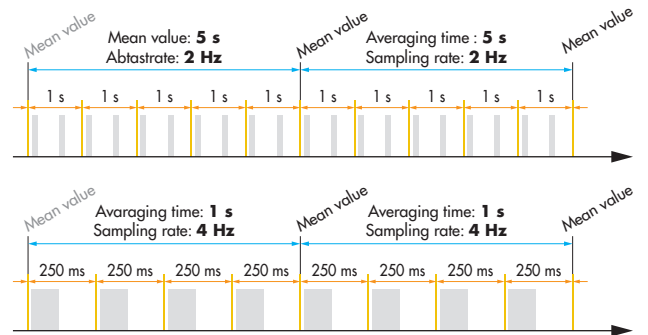

**Continuous measurement, floating mode:**

In the floating mode, samplings are also taken continuously one after the other, and starting from the most recent value, the calculation of the mean value is carried out backwards. The OTT RLS 500 (HF) also immediately responds to an **aRx!** command with a measured value. This value is updated every second.

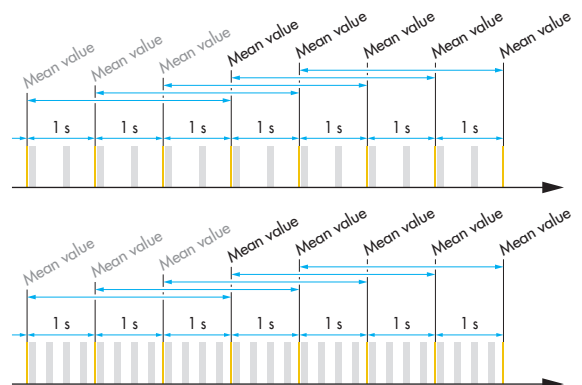

| Command                                       | Response                             |
|---|--------------------------------------|
| ▶ Set/read offset for water level measurement |                                      |
| <code>aXAB&lt;value&gt;!</code>               | <code>at1&lt;CR&gt;&lt;LF&gt;</code> |
| <code>aXAB!</code>                            |                                      |

### Description

Set offset value  
 Read offset value  
**a** – sensor address  
**<value>** – `pbbbb.eee`<sup>1)</sup>  
 Input/output without leading zero!  
 Value range: -9999.999 ... +9999.999  
 Factory setting: +0.000

With this command, you can apply a linear offset (positive/negative) to a level measurement value. After setting the offset, the OTT RLS 500 (HF) automatically starts a measurement. Then check the measured value with the `aD0!` command.

**Please note:** This command overwrites a possibly set reference value!

### Example

Measured value = +10.040 m  
 Offset = -0.200 m  
 Output = +9.840 m

### Notes

- A subsequent change of the unit (`aXSU<value>!`) may result in rounding errors of  $\pm 0.001$ .
- If a measurement is already active or an error has occurred, the OTT RLS 500 (HF) responds with a service request (`a<CR><LF>`).

▶ Set/read reference value for level/depth measurement

|                                 |   |
|---------------------------------|---|
| <code>aXAC&lt;value&gt;!</code> | <code>at1&lt;CR&gt;&lt;LF&gt;</code>            |
| <code>aXAC!</code>              | <code>a&lt;value&gt;&lt;CR&gt;&lt;LF&gt;</code> |

Set reference value  
 Read reference value  
**a** – sensor address  
**<value>** – `pbbbb.eee`<sup>1)</sup>  
 Input/output without leading zeros!  
 Value range: -9999.999 ... +9999.999  
 Factory setting: +0.000

With this command, you can establish, for example, a reference to a level zero point during level measurement by entering a reference value. After setting the reference value, the OTT RLS 500 (HF) automatically starts a measurement. Then check the measured value with the `aD0!` command.

**Please note:** This command overwrites a possibly set offset value!

### Example

Measured value = +2.100 m  
 Reference value = +1.500 (HF) m  
 Output = +1.500 (HF) m  
 (Offset calculated by the OTT RLS 500 (HF) and applied to all other measured values = +0,600 m)

### Notes

- A subsequent change of the unit (`aXSU<value>!`) may result in rounding errors of  $\pm 0.001$ .
- If a measurement is already active or an error has occurred, the OTT RLS 500 (HF) does not respond.

<sup>1)</sup> depending on the set unit; extended command `aXSU<value>!`

| Command   | Response                                  | Description   |
|---|---|---|
| ▶ Reset/read all units to default (metric or imperial)                    |   |   |
| <b>aXSR&lt;value&gt;!</b>   | <b>a&lt;value&gt;&lt;CR&gt;&lt;LF&gt;</b> | Reset units to default  |
| <b>aXSR!</b>  | <b>a&lt;value&gt;&lt;CR&gt;&lt;LF&gt;</b> | Read default units  |
|   |   | <b>a</b> – sensor address<br><b>&lt;value&gt;</b> – +0: metric<br>+1: imperial<br>+2: individual customer setting<br>(only for reading)   |
|   |   | This command resets all – potentially individually changed – units to metric or imperial values (according to the delivery state). The factory setting depends on the ordered variant code.   |
| ▶ Reset radar sensor to factory settings without communication settings   |   |   |
| <b>aXSF!</b>  | <b>a&lt;CR&gt;&lt;LF&gt;</b>              | Reset radar sensor  |
|   |   | <b>a</b> – sensor address<br>Resets all settings to factory values (delivery state according to the ordered variant code).<br>Individually changed communication settings on the RS-485 interface (Modbus, SDI-12) remain unchanged.<br>RS-485 protocol → unchanged<br>Units → default metric or imperial   |
| ▶ Reset radar sensor to factory settings including communication settings |   |   |
| <b>aXSF+1!</b>  | <b>a&lt;CR&gt;&lt;LF&gt;</b>              | Reset radar sensor  |
|   |   | <b>a</b> – sensor address<br>Resets all settings to factory values – including potentially changed communication settings on the RS-485 interface (Modbus, SDI-12) (delivery state according to the ordered variant code).<br>RS-485 protocol → – Modbus; measurement type continuous measurement, interval mode<br>– SDI-12; measurement type single measurement<br>Units → default metric or imperial   |
| ▶ Set calculation method discharge measurement                            |   |   |
| <b>aXDC&lt;value&gt;!</b>   | <b>a&lt;value&gt;&lt;CR&gt;&lt;LF&gt;</b> | Set calculation method  |
| <b>aXDC!</b>  | <b>a&lt;value&gt;&lt;CR&gt;&lt;LF&gt;</b> | Read calculation method   |
|   |   | <b>a</b> – sensor address<br><b>&lt;value&gt;</b> – +0: deactivated; factory setting<br>+1: activated, calculation method W/Q table<br>+2 activated calculation method according to Standard ISO 1100-2, exponential formula<br>$Q = p(h-e)^\beta$ <b>h</b> = level at water surface<br><b>e</b> = effective level at discharge = 0<br><b>β</b> = gradient of the rating curve<br><b>p</b> = constant which numerically corresponds to discharge at (h-e) = 1 |

<sup>1)</sup> depending on the set unit; extended command **aXSU<value>!**

| Command  | Response  | Description  |
|--|---|--|
| ▶ Create table entry in rating table (calculation method rating table)                       |   |  |
| <code>aXD&lt;value1&gt;...&lt;value2&gt;!</code>   | <code>a&lt;value1&gt;&lt;value2&gt;&lt;CR&gt;&lt;LF&gt;</code>                  | <p>Create table entry</p> <p><b>a</b> – sensor address</p> <p><b>&lt;value1&gt;</b> – water level at related discharge</p> <p><b>&lt;value2&gt;</b> – discharge at related water level</p> <p><b>Notes:</b></p> <ul style="list-style-type: none"> <li>– precondition: calculation method rating table activated</li> <li>– maximum 50 table entries</li> <li>– entries are sorted automatically</li> <li>– unit water level: as specified by <b>aXSU!</b></li> <li>– unit discharge: as specified by <b>aXSD!</b></li> </ul> <p><b>Example:</b></p> <p><code>aXD&lt;+5.750&gt;&lt;+63.000&gt;!</code></p> |
| ▶ Enter coefficient for discharge measurement (calculation method exponential formula)       |   |  |
| <code>aXD&lt;value1&gt;...&lt;value2&gt;...&lt;value3&gt;!</code>                            | <code>a&lt;value1&gt;&lt;value2&gt;&lt;value3&gt;...&lt;CR&gt;&lt;LF&gt;</code> | <p>Set coefficient</p> <p><b>a</b> – sensor address</p> <p><b>&lt;value1&gt;</b> – factor "e" of exponential formula; offset; factory setting: +0.000</p> <p><b>&lt;value2&gt;</b> – factor "p" of exponential formula; scaling; factory setting: +1.000</p> <p><b>&lt;value3&gt;</b> – factor "β" of exponential formula; exponent; factory setting: +1.000</p> <p><b>Note:</b></p> <p>precondition: calculation method exponential formula activated.</p> <p><b>Example:</b></p> <p><code>aXD&lt;+1.260&gt;&lt;+21.800&gt;&lt;+2.540&gt;!</code></p>   |
| ▶ Read table entry in rating table (calculation method rating table)                         |   |  |
| <code>aXDR&lt;value1&gt;!</code>   | <code>a&lt;value2&gt;&lt;value3&gt;&lt;CR&gt;&lt;LF&gt;</code>                  | <p>Read table entry</p> <p><b>a</b> – sensor address</p> <p><b>&lt;value1&gt;</b> – entry (index) in the table to read out</p> <p><b>&lt;value2&gt;</b> – water level at related discharge</p> <p><b>&lt;value3&gt;</b> – discharge at related water level</p> <p><b>Notes:</b></p> <ul style="list-style-type: none"> <li>– precondition: calculation method rating table activated</li> <li>– entries are sorted automatically</li> <li>– unit water level: as specified by <b>aXSU!</b></li> <li>– unit discharge: as specified by <b>aXSD!</b></li> </ul>  |
| ▶ Read number of entries in rating table (calculation method rating table)                   |   |  |
| <code>aXDR!</code>   | <code>a&lt;value&gt;&lt;LF&gt;</code>   | <p>Read number of table entries</p> <p><b>a</b> – sensor address</p> <p><b>&lt;value&gt;</b> – number of table entries</p> <p><b>Note:</b></p> <p>precondition: calculation method rating table activated</p>  |
| ▶ Read coefficient exponential formula (calculation method according to Standard ISO 1100-2) |   |  |
| <code>aXDR!</code>   | <code>a&lt;value1&gt;&lt;value2&gt;&lt;value3&gt;...&lt;CR&gt;&lt;LF&gt;</code> | <p>Read coefficient</p> <p><b>a</b> – sensor address</p> <p><b>&lt;value1&gt;</b> – factor "e" of exponential formula; offset;</p> <p><b>&lt;value2&gt;</b> – factor "p" of exponential formula; scaling;</p> <p><b>&lt;value3&gt;</b> – factor "β" of exponential formula; exponent</p> <p><b>Note:</b> precondition: calculation method exponential formula activated</p>  |

| Command   | Response                                  | Description   |
|---|---|---|
| ▶ Delete table entry in rating table (calculation method rating table)              |   |   |
| <b>aXDD&lt;value&gt;!</b>   | <b>a&lt;CR&gt;&lt;LF&gt;</b>              | Delete table entry<br>a – sensor address<br><value> – entry (index) in the table to be deleted<br><b>Note:</b> precondition: calculation method rating table activated  |
| ▶ Delete rating table completely (calculation method rating table)                  |   |   |
| <b>aXDD+9999!</b>   | <b>a&lt;CR&gt;&lt;LF&gt;</b>              | Delete rating table completely<br>a – sensor address<br>This command deletes a rating table completely.<br><b>Note:</b><br>– precondition: calculation method rating table activated and at least one table entry is available.   |
| ▶ For device variant OTT RLS 500 HF: set/read sampling rate of distance measurement |   |   |
| <b>aXXD&lt;value&gt;!</b>   | <b>a&lt;value&gt;&lt;CR&gt;&lt;LF&gt;</b> | Set sampling rate of distance measurement   |
| <b>aXXD!</b>  | <b>a&lt;value&gt;&lt;CR&gt;&lt;LF&gt;</b> | Read sampling rate<br>a – sensor address<br><value> – +1: 2 Hz (2 samplings/s)<br>+2: 4 Hz (4 samplings/s)<br>+3: 8 Hz (8 samplings/s)<br>Factory setting: +1 → 2 Hz  |
| ▶ Set/read error indicator for incorrect distance measurement                       |   |   |
| <b>aXSI&lt;value&gt;!</b>   | <b>a&lt;value&gt;&lt;CR&gt;&lt;LF&gt;</b> | Set error indicator for incorrect distance measurement  |
| <b>aXSI!</b>  |   | Read error indicator<br>a – sensor address<br><value> – pbbbbbb.eee<br>Input/output without leading zero!<br>Value range: -9999.999 ... +9999.999<br>+10000.000<br>Factory setting: +9999.999 meters<br><b>Notes:</b><br>– This value is output in the event of incorrect, undetectable or invalid measured values (number of measured values within a measurement interval = 0).<br>– The unit is identical with the unit set for water level measured values ( <b>aXAA&lt;value&gt;!</b> ).<br>– The setting "+10000.000" outputs the last valid measured value instead of the error indicator.<br>– The error indicator is used for the water level measured values "mean value", "maximum value", "minimum value", "median" and "standard deviation". |

| Command  | Response         | Description   |
|--|------------------|---|
| ▶ RS-485 interface: set/read Modbus (RTU) address                        |                  |   |
| aXCA<value>!   | a<value><CR><LF> | Set Modbus (RTU) address  |
| aXCA!  | a<value><CR><LF> | Read Modbus (RTU)address  |
|  |                  | <b>a</b> – sensor address<br><b>&lt;value&gt;</b> – +bbb<br>Input/output without leading zeros!<br>Value range: +1 ... +247<br>Factory setting: +1<br><b>Note:</b> Modbus transmission parameters are changed immediately; any communication already in progress is immediately affected.   |
| ▶ RS-485 interface: set/read Modbus (RTU) transmission speed (baud rate) |                  |   |
| aXCB<value>!   | a<value><CR><LF> | Set baud rate   |
| aXCB!  | a<value><CR><LF> | Read baud rate  |
|  |                  | <b>a</b> – sensor address<br><b>&lt;value&gt;</b> – +0: 9 600 bit/s<br>+1: 19 200 bit/s<br>+2: 115 200 bit/s<br>Factory setting: +0 → 9 600 bit/s<br><b>Note:</b> Modbus transmission parameters are changed immediately; any communication already in progress is immediately affected.  |
| ▶ RS-485 interface: Set/read Modbus (RTU) parity                         |                  |   |
| aXCP<value>!   | a<value><CR><LF> | Set parity  |
| aXCP!  | a<value><CR><LF> | Read parity   |
|  |                  | <b>a</b> – sensor address<br><b>&lt;value&gt;</b> – +0: none, 1 Stop bit (8N1)<br>+1: none, 2 Stop bits (8N2)<br>+2: odd, 1 Stop bit (8O1)<br>+3: even, 1 Stop bit (8E1)<br>Factory setting: +3 → even, 1 Stoppbit<br><b>Note:</b> Modbus transmission parameters are changed immediately; any communication already in progress is immediately affected. |

## 8 RS-485 interface with Modbus protocol (RTU)

### 8.1 Preconditions

|   |   |
|---|---|
| ▶ OTT RLS 500 (HF) variant code:<br>→ protocol RS-485 interface | M (first position of variant code)<br>Modbus                                  |
| ▶ Measurement type  | continuous measurement (interval mode or floating mode)                       |
| ▶ Interface   | EIA-485 (RS-485)  |
| ▶ Transmission parameters                                       | 8 data bits, even parity, 1 Stop bit (8E1; factory setting),<br>8N1, 8N2, 8O1 |
| ▶ Transmission speed  | 9 600 (factory setting), 19 200, 115 200                                      |
| ▶ Bus address   | 1 ... 247   |

### 8.2 Value ranges

#### 16-bit integer values

| Modbus Register | 1  |    |    |    |    |    |   |   |   |   |   |   |   |   |   |   |
|-----------------|----|----|----|----|----|----|---|---|---|---|---|---|---|---|---|---|
| Byte            | 0  |    |    |    |    |    |   |   | 1 |   |   |   |   |   |   |   |
| Bit             | 15 | 14 | 13 | 12 | 11 | 10 | 9 | 8 | 7 | 6 | 5 | 4 | 3 | 2 | 1 | 0 |

int range: -32767 ... 32767

uint range: 0 ... 65534

bitfield16 range: 0 ... 0x7FFF

#### 32-bit integer values

| Modbus Register | 1         |  |           |  | 2         |  |           |  |
|-----------------|-----------|--|-----------|--|-----------|--|-----------|--|
| Byte            | 0         |  | 1         |  | 2         |  | 3         |  |
| Bit             | 31 ... 24 |  | 23 ... 16 |  | 15 ... 08 |  | 07 ... 00 |  |

int range: -214483647 ... 214483647

uint range: 0 ... 4294967294

#### Floating point values

| Modbus Register | 1    |          |    |    |    |    |    |    |          |    |    |    |    |    |    |    |
|-----------------|------|----------|----|----|----|----|----|----|----------|----|----|----|----|----|----|----|
| Byte            | 0    |          |    |    |    |    |    |    | 1        |    |    |    |    |    |    |    |
| Bit             | 31   | 30       | 29 | 28 | 27 | 26 | 25 | 24 | 23       | 22 | 21 | 20 | 19 | 18 | 17 | 16 |
| IEEE 754        | sign | Exponent |    |    |    |    |    |    | Fraction |    |    |    |    |    |    |    |

| Modbus Register | 2              |    |    |    |    |    |   |   |   |   |   |   |   |   |   |   |
|-----------------|----------------|----|----|----|----|----|---|---|---|---|---|---|---|---|---|---|
| Byte            | 2              |    |    |    |    |    |   |   | 3 |   |   |   |   |   |   |   |
| Bit             | 15             | 14 | 13 | 12 | 11 | 10 | 9 | 8 | 7 | 6 | 5 | 4 | 3 | 2 | 1 | 0 |
| IEEE 754        | Fraction least |    |    |    |    |    |   |   |   |   |   |   |   |   |   |   |

float32 range: see IEEE 754

#### String value

| Modbus Register | 1 | 2 | 3 | 4 | 5 | 6 | 7 | 8    |
|-----------------|---|---|---|---|---|---|---|------|
| Byte            | 0 | 1 | 2 | 3 | 4 | 5 | 6 | 7    |
| Bit             | E | X | A | M | P | L | E | spc  |
|                 | S | T | R | I | N | G | ! | NULL |

- **Remark:** The OTT RLS 500 (HF) has only one "Holding Register" Block.

### 8.3 Sensor description register

| Register name                                | Register-number <sup>1)</sup> | Data type      | Length | Access mode | min. / max. | Description  |
|--|-------------------------------|----------------|--------|-------------|-------------|--|
| ▶ Protocol ID                                | 1 (0)                         | uint 32        | 2      | R           |             | OTT HydroMet device assignment starting with register number 41001 and beginning with the 32-bit OTTP identifier. This enables the detection of devices that are compatible with the OTT HydroMet Modbus protocol. |
| ▶ ID protocol-description                    | 3 (2)                         | uint 16        | 1      | R           |             | 0x0001 "Common Block"  |
| ▶ Length of protocol description             | 4 (3)                         | uint 16        | 1      | R           |             | Total number of 16-bit registers for protocol description  |
| ▶ Product ID                                 | 5 (4)                         | Integer 32 bit | 2      | R           |             | Product ID 63110 (0x0000F686)  |
| ▶ Device ID                                  | 7 (6)                         | Integer 32 bit | 2      | R           |             | Device ID 001 (0x00000001)   |
| ▶ Firmware version                           | 9 (8)                         | Integer 32 bit | 2      | R           |             | V1.23.4 = 123400 (0x0001E208)  |
| ▶ Bootloader version                         | 11 (10)                       | Integer 32 bit | 1      | R           |             | V1.23.4 = 123400 (0x0001E208)  |
| ▶ Reference system physical elements         | 13 (12)                       | uint 16        | 1      | R           |             | 0x001 = SHEF (default)<br>0x002 = OTT  |
| ▶ Reference system units                     | 14 (13)                       | uint 16        | 1      | R           |             | 0x001 = SHEF<br>0x002 = OTT (default)  |
| ▶ Number of channels                         | 15 (14)                       | uint 16        | 1      | R           | 1 ... 40    | Number of sensor channels: 13  |
| ▶ Channel 1 – definition of physical element | 16 (15)                       | uint 16        | 1      | R           |             | Mean value of water level over the averaging period<br>HA, Height of reading (0x4841)<br>HB, Depth of reading (0x4842)   |
| ▶ Channel 1 – unit                           | 17 (16)                       | uint 16        | 1      | R           |             | 0x0002: M<br>0x0003: CM<br>0x0004: FT<br>0x0005: INCH<br><br>0x0006: MM (no SHEF code)   |
| ▶ Channel 1 – unit string                    | 18 (17)                       | uint 16        | 3      | R           |             | e.g. CM<br>(the register is 3 x 16 bits long and contains a char [6] array)  |
| ▶ Channel 2 – definition of physical element | 21 (20)                       | uint 16        | 1      | R           |             | Quality indicator of water level measurement   |
| ▶ Channel 2 – unit                           | 22 (21)                       | uint 16        | 1      | R           |             | none   |
| ▶ Channel 2 – unit string                    | 23 (22)                       | uint 16        | 3      | R           |             | compare "Channel 1: unit string"   |
| ▶ Channel 3 – definition of physical element | 26 (25)                       | uint 16        | 1      | R           |             | last single measured level value<br>HA, Height of reading (0x4841)<br>HB, Depth of reading (0x4842)  |
| ▶ Channel 3 – unit                           | 27 (26)                       | uint 16        | 1      | R           |             | 0x0002: M<br>0x0003: CM<br>0x0004: FT<br>0x0005: INCH<br><br>0x0006: MM (no SHEF code)   |

<sup>1)</sup> the corresponding register start addresses are given in brackets (register number - 1 = register start adresse)



| Register name                                | Register-number <sup>1)</sup> | Data type | Length | Access mode | min. / max. | Description  |
|--|-------------------------------|-----------|--------|-------------|-------------|--|
| ▶ Channel 3 – unit string                    | 28 (27)                       | uint 16   | 3      | R           |             | compare "Channel 1: unit string"   |
| ▶ Channel 4 – definition of physical element | 31 (30)                       | uint 16   | 1      | R           |             | Minimum level value within the averaging time<br>HA, Height of reading (0x4841)<br>HB, Depth of reading (0x4842)               |
| ▶ Channel 4 – unit                           | 32 (31)                       | uint 16   | 1      | R           |             | 0x0002: M<br>0x0003: CM<br>0x0004: FT<br>0x0005: INCH<br><br>0x0006: MM (no SHEF code)   |
| ▶ Channel 4 – unit string                    | 33 (32)                       | uint 16   | 3      | R           |             | compare "Channel 1: unit string"   |
| ▶ Channel 5 – definition of physical element | 36 (35)                       | uint 16   | 1      | R           |             | Maximum level value within the averaging time<br>HA, Height of reading (0x4841)<br>HB, Depth of reading (0x4842)               |
| ▶ Channel 5 – unit                           | 37 (36)                       | uint 16   | 1      | R           |             | 00x0002: M<br>0x0003: CM<br>0x0004: FT<br>0x0005: INCH<br><br>0x0006: MM (kein SHEF Code)                                      |
| ▶ Channel 5 – unit string                    | 38 (37)                       | uint 16   | 3      | R           |             | compare "Channel 1: unit string"   |
| ▶ Channel 6 – definition physical element    | 41 (40)                       | uint 16   | 1      | R           |             | Median level value over the averaging period<br>HA, Height of reading (0x4841)<br>HB, Depth of reading (0x4842)                |
| ▶ Channel 6 – unit                           | 42 (41)                       | uint 16   | 1      | R           |             | 0x0002: M<br>0x0003: CM<br>0x0004: FT<br>0x0005: INCH<br><br>0x0006: MM (no SHEF code)   |
| ▶ Channel 6 – unit string                    | 43 (42)                       | uint 16   | 3      | R           |             | compare "Channel 1: unit string"   |
| ▶ Channel 7 – definition of physical element | 46 (45)                       | uint 16   | 1      | R           |             | Standard deviation of level value over the averaging period<br>HA, Height of reading (0x4841)<br>HB, Depth of reading (0x4842) |
| ▶ Channel 7 – unit                           | 47 (46)                       | uint 16   | 1      | R           |             | 0x0002: M<br>0x0003: CM<br>0x0004: FT<br>0x0005: INCH<br><br>0x0006: MM (no SHEF Code)   |
| ▶ Channel 7 – unit string                    | 48 (47)                       | uint 16   | 3      | R           |             | compare "Channel 1: unit string"   |

<sup>1)</sup> the corresponding register start addresses are given in brackets (register number - 1 = register start address)

| Register name                                 | Register-number <sup>1)</sup> | Data type | Length | Access mode | min. / max. | Description  |
|---|-------------------------------|-----------|--------|-------------|-------------|--|
| ▶ Channel 8 – definition of physical element  | 51 (50)                       | uint 16   | 1      | R           |             | Device status OS, Status of device (0x4f53)                            |
| ▶ Channel 8 – unit                            | 52 (51)                       | uint 16   | 1      | R           |             | 0x0001: none   |
| ▶ Channel 8 – unit string                     | 53 (52)                       | uint 16   | 3      | R           |             | compare "Channel 1: unit string"                                       |
| ▶ Channel 9 – definition of physical element  | 56 (55)                       | uint 16   | 1      | R           |             | relative humidity in the probe housing XR, Humidity, relative (0x5852) |
| ▶ Channel 9 – unit                            | 57 (56)                       | uint 16   | 1      | R           |             | 0x0010: %  |
| ▶ Channel 9 – unit string                     | 58 (57)                       | uint 16   | 3      | R           |             | compare "Channel 1: unit string"                                       |
| ▶ Channel 10 – definition of physical element | 61 (60)                       | uint 16   | 1      | R           |             | Dew point in the probe housing TD, Dew point (0x5444)                  |
| ▶ Channel 10 – unit                           | 62 (61)                       | uint 16   | 1      | R           |             | 0x0010: DEGREE C<br>0x0011: DEGREE F<br>0x0012: Kelvin (no SHEF code)  |
| ▶ Channel 10 – unit string                    | 63 (62)                       | uint 16   | 3      | R           |             | compare "Channel 1: unit string"                                       |
| ▶ Channel 11 – definition of physical element | 66 (65)                       | uint 16   | 1      | R           |             | Temperature in the probe housing TA, Temperature of air (0x5441)       |
| ▶ Channel 11 – unit                           | 67 (66)                       | uint 16   | 1      | R           |             | 0x0010: DEGREE C<br>0x0011: DEGREE F<br>0x0012: Kelvin (no SHEF code)  |
| ▶ Channel 11 – unit string                    | 68 (67)                       | uint 16   | 3      | R           |             | compare "Channel 1: unit string"                                       |
| ▶ Channel 12 – definition of physical element | 71 (70)                       | uint 16   | 1      | R           |             | current sensor orientation X-axis<br>0x0001: not defined               |
| ▶ Channel 12 – unit                           | 72 (71)                       | uint 16   | 1      | R           |             | 0x0010: degree   |
| ▶ Channel 12 – unit string                    | 73 (72)                       | uint 16   | 3      | R           |             | compare "Channel 1: unit string"                                       |
| ▶ Channel 13 – definition of physical element | 76 (75)                       | uint 16   | 1      | R           |             | current sensor orientation Y-axis<br>0x0001: not defined               |
| ▶ Channel 13 – unit                           | 77 (76)                       | uint 16   | 1      | R           |             | 0x0010: degree   |
| ▶ Channel 13 – unit string                    | 78 (77)                       | uint 16   | 3      | R           |             | compare "Channel 1: unit string"                                       |

<sup>1)</sup> the corresponding register start addresses are given in brackets (register number - 1 = register start adresse)

| Register name                                 | Register-number <sup>1)</sup> | Data type | Length | Access mode | min. / max. | Description   |
|---|-------------------------------|-----------|--------|-------------|-------------|---|
| ▶ Channel 14 – definition of physical element | 81 (80)                       | uint 16   | 1      | R           |             | saved sensor orientation X-axis<br>0x0001: not defined  |
| ▶ Channel 14 – unit                           | 82 (81)                       | uint 16   | 1      | R           |             | 0x0010: degree  |
| ▶ Channel 14 – unit string                    | 83 (82)                       | uint 16   | 3      | R           |             | compare "Channel 1: unit string"  |
| ▶ Channel 15 – definition of physical element | 86 (85)                       | uint 16   | 1      | R           |             | saved sensor orientation Y-axis<br>0x0001: not defined  |
| ▶ Channel 15 – unit                           | 87 (86)                       | uint 16   | 1      | R           |             | 0x0010: degree  |
| ▶ Channel 15 – unit string                    | 88 (87)                       | uint 16   | 3      | R           |             | compare "Channel 1: unit string"  |
| ▶ Channel 16 – definition of physical element | 91 (90)                       | uint 16   | 1      | R           |             | Discharge<br>QR, Discharge river (0x5152)   |
| ▶ Channel 16 – unit                           | 92 (91)                       | uint 16   | 1      | R           |             | 0x0002: Cubic meters per second<br>[m <sup>3</sup> /s]<br>0x0003: Liter per second [l <sup>3</sup> /s]<br>0x0004: Cubic feet per second<br>[ft <sup>3</sup> /s] |
| ▶ Channel 16 – unit string                    | 93 (92)                       | uint 16   | 3      | R           |             | compare "Channel 1: unit string"  |

#### 8.4 Register of sensor values

| Register name | Register-number <sup>1)</sup> | Data type | Length | Access mode | min. / max. | Description  |
|---------------|-------------------------------|-----------|--------|-------------|-------------|--|
| ▶ Channel 1   | 201 (200)                     | float 32  | 2      | R           |             | Mean value of water level over the averaging period  |
| ▶ Channel 2   | 203 (202)                     | float 32  | 2      | R           |             | Quality indicator of water level measurement<br>0: no radar signal<br>1: weak radar signal<br>2: medium radar signal<br>3: strong radar signal |
| ▶ Channel 3   | 205 (204)                     | float 32  | 2      | R           |             | Last single measured level value   |
| ▶ Channel 4   | 207 (206)                     | float 32  | 2      | R           |             | Minimum level value within the averaging time  |
| ▶ Channel 5   | 209 (208)                     | float 32  | 2      | R           |             | Maximum level value within the averaging time  |
| ▶ Channel 6   | 211 (210)                     | float 32  | 2      | R           |             | Median of level value over the averaging period  |
| ▶ Channel 7   | 213 (212)                     | float 32  | 2      | R           |             | Standard deviation of level value within the averaging time  |
| ▶ Channel 8   | 215 (214)                     | uint 32   | 2      | R           |             | Device status  |

<sup>1)</sup> the corresponding register start addresses are given in brackets (register number - 1 = register start address)

| Register name | Register-number <sup>1)</sup> | Data type | Length | Access mode | min. / max. | Description                            |
|---------------|-------------------------------|-----------|--------|-------------|-------------|--|
| ▶ Channel 9   | 217 (216)                     | float 32  | 2      | R           |             | Relative humidity in the probe housing |
| ▶ Channel 10  | 219 (218)                     | float 32  | 2      | R           |             | Dew point in the probe housing         |
| ▶ Channel 11  | 221 (220)                     | float 32  | 2      | R           |             | Temperature in the probe housing       |
| ▶ Channel 12  | 223 (222)                     | float 32  | 2      | R           |             | current sensor orientation X-axis      |
| ▶ Channel 13  | 225 (224)                     | float 32  | 2      | R           |             | current sensor orientation Y-axis      |
| ▶ Channel 14  | 227 (226)                     | float 32  | 2      | R           |             | saved sensor orientation X-axis        |
| ▶ Channel 15  | 229 (228)                     | float 32  | 2      | R           |             | saved sensor orientation Y-axis        |
| ▶ Channel 16  | 231 (230)                     | float 32  | 2      | R           |             | Discharge                              |

## 8.5 Configuration register

Register values/factory settings are described in Chapter 7 *SDI-12 commands and responses*.

Changes to the Modbus communication settings will cause a Modbus timeout because the internal communication is restarted and the stack cannot respond. Successful changes are answered with a regular Modbus response, invalid data with "illegal data value" and unsupported register addresses with "illegal data address".

**Please note:** Changes to the SD-112 address will reset the entire system and cause a Modbus timeout.

| Register name   | Register-number <sup>1)</sup> | Data type | Length | Access mode | Description  |
|---|-------------------------------|-----------|--------|-------------|--|
| Unit water level  | 301 (300)                     | uint 16   | 1      | R/W         | Setting unit for level                                 |
| Unit temperature  | 302 (301)                     | uint 16   | 1      | R/W         | Setting unit for temperature                           |
| Unit discharge  | 304 (303)                     | uint 16   | 1      | R/W         | Setting unit for discharge                             |
| Calculation method discharge                                  | 305 (304)                     | uint 16   | 1      | R/W         | Setting calculation method discharge                   |
| Units imperial/metric   | 306 (305)                     | uint 16   | 2      | R/W         | Select presetting of units                             |
| Depth measurement   | 307 (306)                     | uint 16   | 2      | R/W         | Activate depth measurement                             |
| Error indicator for incorrect distance measurement            | 308 (307)                     | uint 16   | 2      | R/W         | Set error indicator for incorrect distance measurement |
| Averaging time  | 309 (308)                     | float 32  | 2      | R/W         | Setting averaging time                                 |
| Continuous measurement  | 311 (310)                     | uint 16   | 1      | R/W         | Activate measurement mode continuous measurement       |
| SDI-12 address  | 312 (311)                     | uint 16   | 2      | R/W         | Setting SDI-12 address                                 |
| Modbus (RTU) bus address                                      | 313 (312)                     | uint 16   | 1      | R/W         | Setting Modbus bus address                             |
| Transmission speed  | 314 (313)                     | uint 16   | 1      | R/W         | Setting Modbus (RTU) transmission speed (baud rate)    |
| Modbus (RTU) parity   | 315 (314)                     | uint 16   | 1      | R/W         | Setting Modbus (RTU) parity                            |
| For OTT RLS 500 HF: Sampling rate of the distance measurement | 317 (316)                     | float 32  | 2      | R/W         | Setting the sampling rate of the distance measurement  |

<sup>1)</sup> the corresponding register start addresses are given in brackets (register number - 1 = register start address)

Settings of the exponential formula ( $Q = p (h - e)^\beta$ ) according to ISO 1100-2:

| Register name                         | Register-number <sup>1)</sup> | Data type | Length | Access mode | Description               |
|---------------------------------------|-------------------------------|-----------|--------|-------------|---------------------------|
| Factor "e" of the exponential formula | 351 (350)                     | float 32  | 2      | R/W         | Coefficient: offset "e"   |
| Factor "p" of the exponential formula | 353 (352)                     | float 32  | 2      | R/W         | Coefficient: scaling "p"  |
| Factor "β" of the exponential formula | 355 (354)                     | float 32  | 2      | R/W         | Coefficient: exponent "β" |

The entries in the rating table can be set using the following two tabs. The value table is sorted in ascending order, therefore it is not possible to write directly into the value table. With the aid of the two registers, the OTT RLS 500 (HF) controls the correct insertion of the values into the rating table. If the maximum table size (50 entries) is reached, a write attempt is answered with "NAK not acknowledge".

To delete a specific entry, enter the water level of the entry to be deleted and a discharge value of "-9999" in the format "float32". To change a specific value, enter the water level of the entry to be changed and a new discharge value.

**Please note:** To correctly change entries in the rating table, the water level register **must be written first**. When writing a value to the discharge register, the register values of water level and discharge are taken over. If the sequence is not observed, both register values will be discarded!

| Register name | Register-number <sup>1)</sup> | Data type | Length | Access mode | Description                               |
|---------------|-------------------------------|-----------|--------|-------------|---|
| Water level   | 361 (360)                     | float 32  | 2      | W           | write water level to associated discharge |
| Discharge     | 363 (362)                     | float 32  | 2      | W           | write discharge to associated water level |

Register values with the entries "Water level" and "Discharge" of the rating table (empty entries are marked by the value "-9999" in the format "float32"):

| Register name  | Register-number <sup>1)</sup> | Data type | Length | Access mode | Description                 |
|----------------|-------------------------------|-----------|--------|-------------|-----------------------------|
| Water level 1  | 401 (400)                     | float 32  | 2      | R           | Table entry 1: Water level  |
| Discharge 1    | 403 (402)                     | float 32  | 2      | R           | Table entry 1: Discharge    |
| Water level 2  | 405 (404)                     | float 32  | 2      | R           | Table entry 2: Water level  |
| Discharge 2    | 407 (406)                     | float 32  | 2      | R           | Table entry 2: Discharge    |
| Water level n  | ...                           | float 32  | 2      | R           | Table entry n: Water level  |
| Discharge n    | ...                           | float 32  | 2      | R           | Table entry n: Discharge    |
| Water level 50 | 597 (596)                     | float 32  | 2      | R           | Table entry 50: Water level |
| Discharge 50   | 599 (598)                     | float 32  | 2      | R           | Table entry 50: Discharge   |

<sup>1)</sup> the corresponding register start addresses are given in brackets (register number - 1 = register start address)

## 9 Carrying out maintenance work

The OTT RLS 500 (HF) radar sensor is almost maintenance free. No setting or calibration work is necessary. Likewise, there are no parts that need replacing regularly.

Carry out the following maintenance work at regular frequencies based on the local circumstances:

- Check the OTT RLS for dirt (e.g. thick, dewy spider's webs or insect nests can lead to impairment of the measured results). In this case, carefully clean the sensor (if necessary use commercial, gentle and non-erasing cleaners and a soft sponge). At the same time, ensure that the setting of the swivel mount does not change.
- Check for obstructions in the measurement beam (for example, for flotsam or branches of trees and bushes growing into this area). In this case, remove all obstructions.
- Check the plausibility of the measured values by comparing with a second sensor or with a staff gauge (e.g. as part of the inspection maintenance).

**!** **Please note:** Never open the housing of the OTT RLS 500 (HF)! There are no adjustment or operating elements inside the housing.

## 10 Troubleshooting

### Sensor does not respond to the SDI-12 interface

- ▶ If present: Is the fuse in the power supply line defective?  
→ Replace fuse.
- ▶ Sensor correctly connected to a datalogger with SDI-12 input?  
→ Correct connection assignment.
- ▶ Polarity of the power supply reversed?  
→ Correct connection assignment.
- ▶ Power supply < 5.5 V or > 28.8 V?  
→ Correct level of voltage supplied (check the length and cross-section of the connection cable).
- ▶ Is the supply voltage not a DC voltage?  
→ Only operate the sensor with DC voltage.

### Sensor does not respond to the RS-485 interface (Modbus)

- ▶ Modbus (RTU) communication parameters set incorrectly?  
→ Check and correct communication parameters.
- ▶ Measurement type set to "One measurement interval"?  
→ Check measurement type and set to "continuous measurement, interval mode" or "continuous measurement, floating mode".

### Measured value varies or is not present

- ▶ Sensor (front plate) dirty?  
→ Carefully clean the sensor; see Chapter 7, *Carrying out maintenance work*.
- ▶ Obstructions in the measurement beam?  
→ Remove obstructions.
- ▶ Sensor aligned at right angles to the water surface?  
→ Correct sensor alignment.
- ▶ Mounting location of the sensor steady (e.g. bridge movement)?  
→ Optimize mounting location.
- ▶ Large metal surfaces near the sensor beam (e.g. piling)?  
→ Optimize mounting location.

### Status messages/-output of interfaces

| Status | Status message/-output   |
|--------|--|
| +0     | no error occurred  |
| +1     | system reset   |
| +2     | distance value not compensated   |
| +4     | measured value of level is too low or measured value of depth too high |
| +8     | sensor orientation changed   |
| +16    | radar sensor is pointing upwards                                       |
| +32    | radar sensor has been reset to factory settings                        |
| +64    | relative humidity in the probe housing was/is above limit value        |

## 11 Repair

- ▶ With a device defect, use Chapter 10, to see if you can resolve the problem yourself.
- ▶ In case of device defects, please contact the repair center of OTT:

OTT Hydromet GmbH  
Repaircenter  
Ludwigstrasse 16  
87437 Kempten · Germany  
Telephone +49 831 5617-433  
Fax +49 831 5617-489  
repair@ott.com



**Please note:** Only have a defective OTT RLS 500 (HF) checked and repaired by the OTT HydroMet repair center! Never make any repairs yourself under any circumstances! Only a qualified repair followed by a final factory test guarantees the specified measuring accuracy. Any repairs or attempted repairs carried out by the customer will result in the loss of any guarantee rights.

## 12 Note about the disposal of old units



### Within the member countries of the European Union

In accordance with the European Union guideline 2012/19/EC, OTT takes back old devices within the member countries of the European Union and disposes of them in an appropriate way. The devices concerned by this are marked with the symbol shown here.

- ▶ For further information on the return process, please contact your local salescontact. You will find the addresses of all sales partners in the internet on "[www.otthydromet.com](http://www.otthydromet.com)". Please take into consideration also the national implementation of the EU guideline 2012/19/EC of your country.

OTT Hydromet GmbH  
Abteilung Logistik  
Ludwigstrasse 16  
87437 Kempten · Germany  
Telephone +49 831 5617-170  
Fax +49 831 5617-179  
logistik@ott.com

### For all other countries

- ▶ Dispose of the OTT RLS 500 (HF) properly after taking out of service.
- ▶ Observe the regulations valid in your country for the disposal of electronic devices!
- ▶ Never put the OTT RLS 500 (HF) into the normal domestic waste!

### Materials used

Housing: AlMgSi1, ASA (UV-stabilised ABS)  
Radom (front plate): TFM PTFE  
Mounting: 1.4301 (V2A)  
Cable sheath: PUR



## 13 Technical data

### Water level

|                                 |  |
|---------------------------------|--|
| Measuring range                 | 0 ... 30 m / 0 ... 99 ft distance to water |
| Resolution                      | 0.001 m · 0.1 cm · 1 mm / 0.001 ft         |
| Accuracy                        |  |
| 0 ... 30 m / 0 ... 98 ft        | ±2 mm / 0.007 ft                           |
| average temperature coefficient | < 3 mm/10 K; max. 5 mm                     |
| Units                           | m · cm · mm · ft, inch                     |
| Beam angle of antenna           | 8°   |
| Radar technology                |  |
| Transmission frequency          | 77 ... 81 GHz                              |
| Type of radar                   | FMCW Radar                                 |
| Frequency band                  | W-band                                     |

### Relative humidity in probe housing

|                              |  |
|------------------------------|--|
| Measuring range              | 0 ... 100 % rH (non-condensing)  |
| Resolution                   | 1 % rH   |
| Accuracy                     | typ. ±2 % rH (10 ... 80 % rH)<br>max. ±3 % rH (0 ... 100 % rH)   |
| Units                        | % rH   |
| Sampling range               |  |
| OTT RLS 500                  | 2 Hz   |
| OTT RLS 500 HF               | 2 Hz · 4 Hz · 8 Hz   |
| Measurement interval         | 1 ... 60 seconds   |
| Supply voltage               | 5.5 ... 28.8 V <sub>DC</sub> , typ. 12/24 V <sub>DC</sub>  |
| Current consumption          |  |
| active                       | < 4 mA   |
| idle                         | < 250 µA   |
| Interfaces                   | SDI-12; Version 1.4<br>RS-485, two-wire; SDI-12 protocol<br>Modbus RTU   |
| Measured physical parameters | – water level / depth to water<br>– relative humidity in the probe housing<br>– sensor orientation   |
| Measured value processing    | – mean value* over a time period<br>– minimum value* within a time interval<br>– maximum value* within a time interval<br>– median* over a time period<br>– standard deviation* over a time period<br>– hydrological discharge (Q)<br>* measured value: water level / depth to water |

|   |   |
|---|---|
| Materials   |   |
| Housing   | AlMgSi1, ASA (UV-stabilised ABS)  |
| Radom (front plate)   | TFM PTFE  |
| Mounting  | 1.4301 (V2A)  |
| Cable   | PUR   |
| Weight (without mounting)                                     | approx. 0.75 kg · approx. 1.5 pounds  |
| Terminal assignment connection/connecting cable               |   |
| red   | Power supply  |
| yellow  | RS-485 B  |
| green   | RS-485 A  |
| grey  | SDI-12 DATA   |
| blue  | GND (ground)  |
| Rotation range of swivel mount                                |   |
| Lateral axis  | ±90 °   |
| Longitudinal axis   | ±15 °   |
| Type of protection  | IP 67 (submersion depth max. 1 m · 3.3 ft;<br>submersion duration max. 7 days)  |
| Dimensions L x W x H  | 137 mm x 134,5 mm x 90 mm · 5.30 in x 4.51 in x 3.35 in   |
| Temperature range   |   |
| Operation   | -40°C ... +70 °C · -40°F ... +158 °F  |
| Storage   | -40°C ... +80 °C · -40°F ... +176 °F  |
| Relative humidity   | 0 ... 100 %   |
| Performance classification in accordance with DIN EN ISO 4373 |   |
| Measurement reliability                                       | Performance class 1   |
| Temperature range   | Temperature class 1   |
| Relative humidity   | Class 1   |
| <b>Product certifications</b>                                 |   |
| CE (EU)   | This device complies with the essential requirements of Radio Equip-<br>ment Directive 2014/53/EU.  |
| FCC (US)  | This device complies with Part 15 of the FCC Rules.<br>Operation is subject to the following conditions:<br>– the equipment must not cause harmful interference;<br>– the equipment must accept any interference received, including<br>interference that may cause undesired operation.<br>Warning: unauthorized modification or changes to this wireless<br>communication equipment will void the right to use it. Changes or<br>modifications to this unit not expressly approved by the party<br>responsible for compliance will void the user's authority to operate<br>the equipment.   |
| IC (CN)   | Canadian Radio Interference-Causing Equipment Regulation,<br>ICES-001.<br>This device complies with Industry Canada license-exempt RSS stan-<br>dard(s). Operation is subject to the following two conditions:<br>– the equipment must not cause harmful interference;<br>– the equipment must accept any interference received, including<br>interference that may cause undesired operation.<br>Warning: unauthorized modification or changes to this wireless<br>communication equipment will void the right to use it. Changes or<br>modifications to this unit not expressly approved by the party<br>responsible for compliance will void the user's authority to operate<br>the equipment. |

## Annex A - Dimensions housing- / wall bracket

**OTT RLS 500 (HF) with housing- and wall bracket**

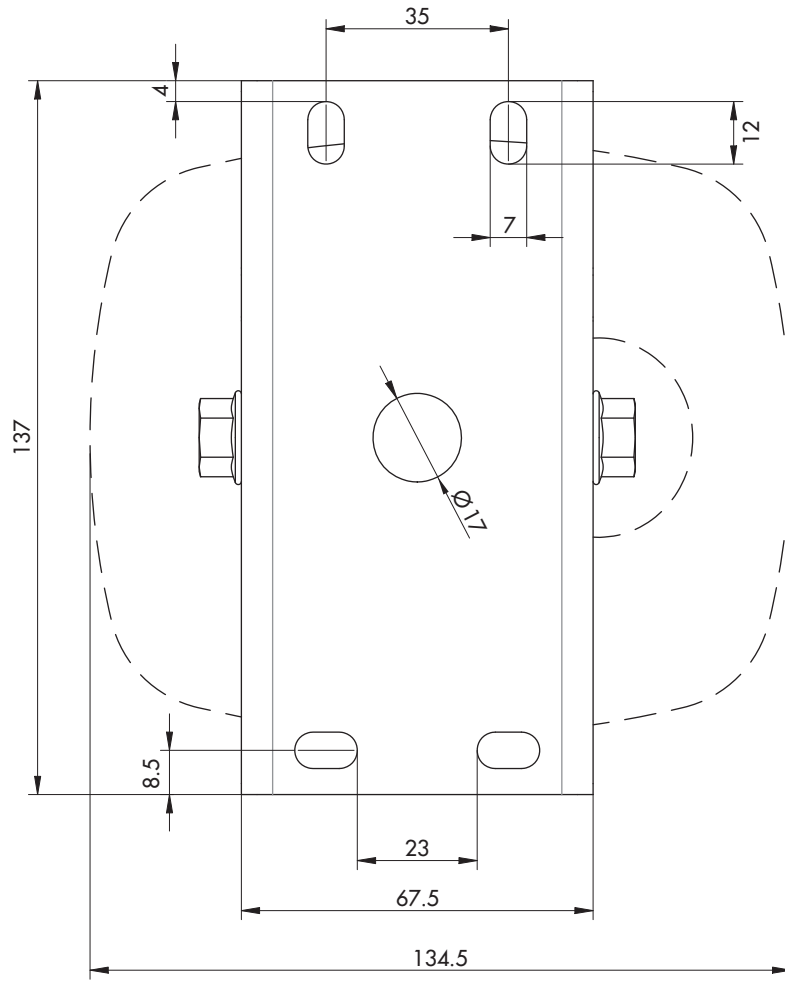

**OTT RLS 500 (HF) with housing bracket**

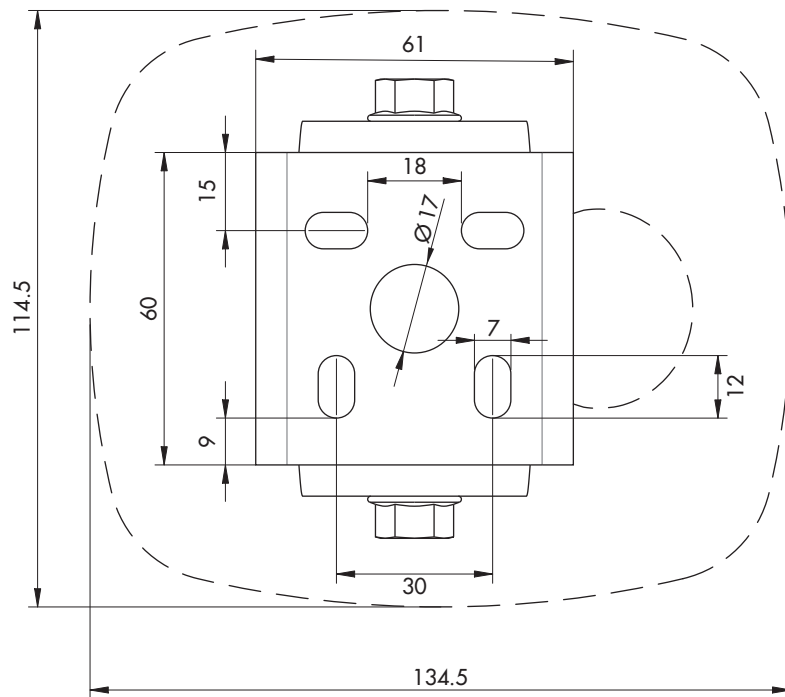

all measures in mm

# Annex B – Definition of X-/Y-axes and direction of rotation

**X-axis**

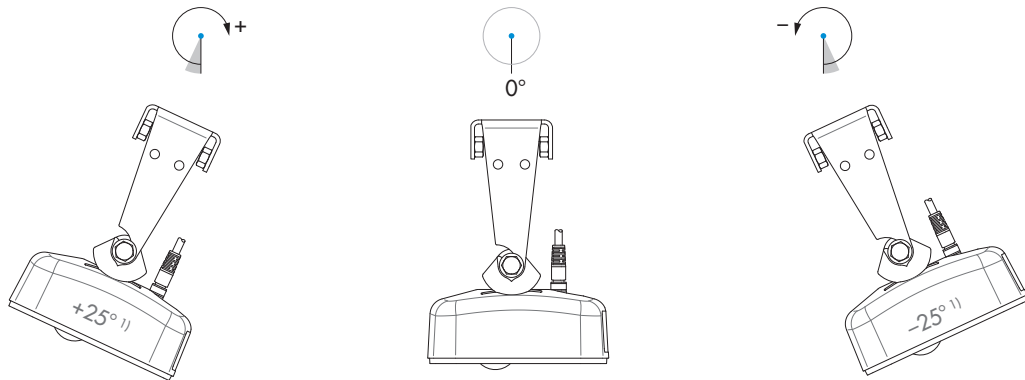

**Y-axis**

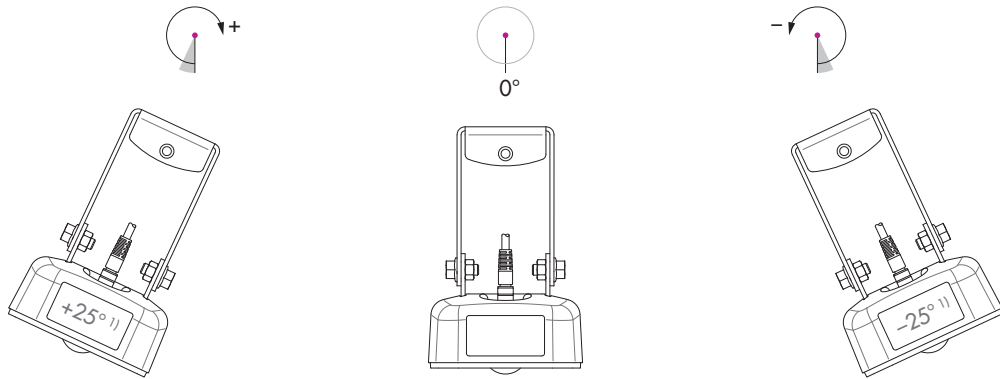

<sup>1)</sup> example rotation shown in the figure

## **Annex C – Note on Declaration of Conformity**

If required, you can download the current version of the Declaration of Conformity for the OTT RLS 500 (HF) as pdf file from our website: "[www.otthydromet.com](http://www.otthydromet.com)".

## **Annex D – Declaration of Health**

If required, you can download the current version of the Declaration of Health for the OTT RLS 500 (HF) as pdf file from our website: "[www.otthydromet.com](http://www.otthydromet.com)".





Document number  
63.110.001.B.E 04-0525



**OTT** HydroMet GmbH  
Ludwigstrasse 16  
87437 Kempten · Germany  
Telephone +49 831 5617-0  
Fax +49 831 5617-209  
euinfo@otthydromet.com  
www.otthydromet.com